

Wild Tulip

Photo on page 7 Instructions on page 75

Emboss line -----
 Line to cut later - - - - -
 Dashed fold line (valley fold) — — —
 Dotted fold line (mountain fold, align pattern to crease)

Paper shown in photo

Flower Petal: Satogami (Yamabuki — golden yellow)

Leaf and Stem: Satogami (Wara — straw)

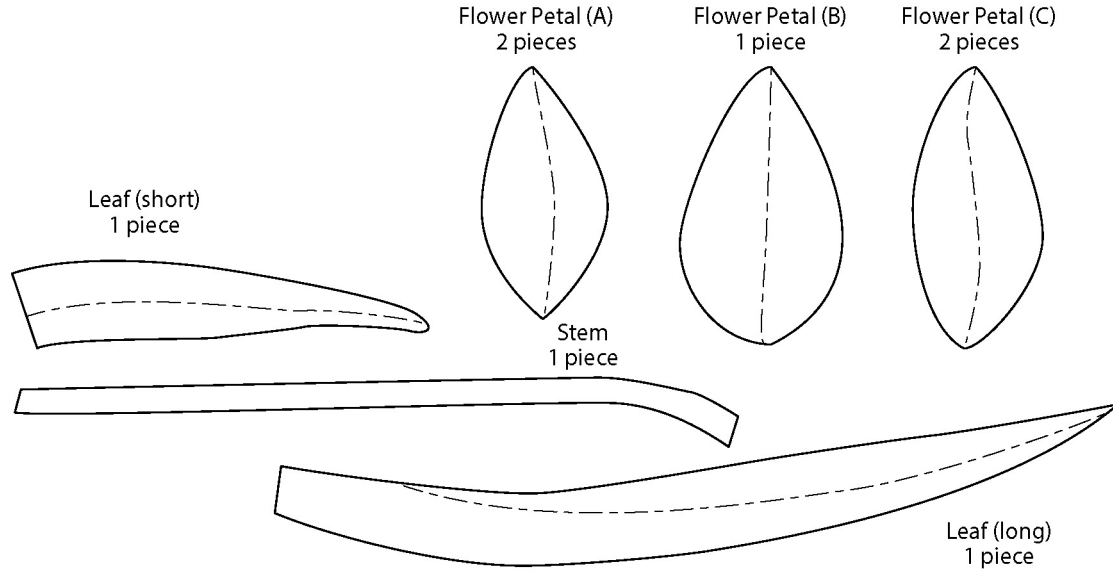

Grape Hyacinth

Photo on page 8 Instructions on page 75

Paper shown in photo

Flower and Bud: Satogami (Kikyo — light purple, Ayame — medium purple)

Leaf and Stem: NT Rasha (light gray-green)

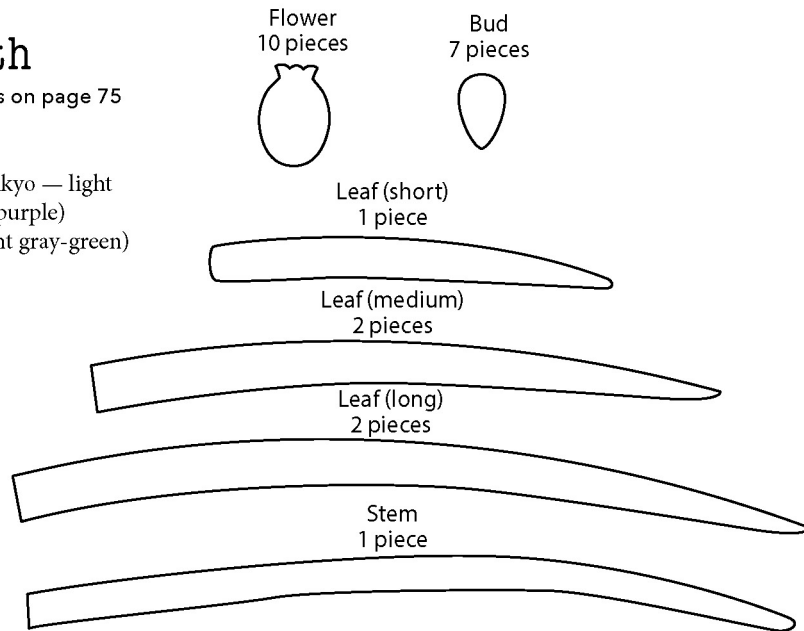

Sweet Pea

Photo on page 9 Instructions on page 76

Emboss line -----
 Line to cut later - - - - -
 Dashed fold line (valley fold) - - - - -
 Dotted fold line (mountain fold, align pattern to crease)

Paper shown in photo

Petal: Tant (G-50, E-50 — both light pink)

Leaf, Stem, Sepal: Satogami (Uri / Gourd — light green)

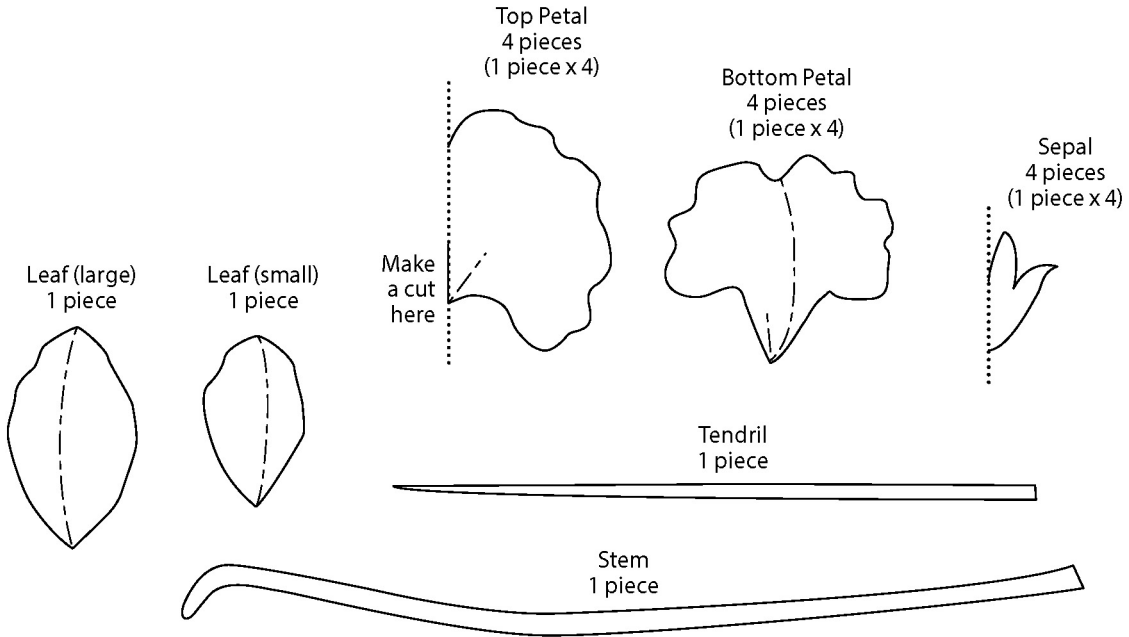

Bluebell

Photo on page 10 Instructions on page 77

Paper shown in photo

Flower: NT Rasha (Lilac — purple)

Leaf and Stem: Satogami (Shida / Fern — medium gray-green)

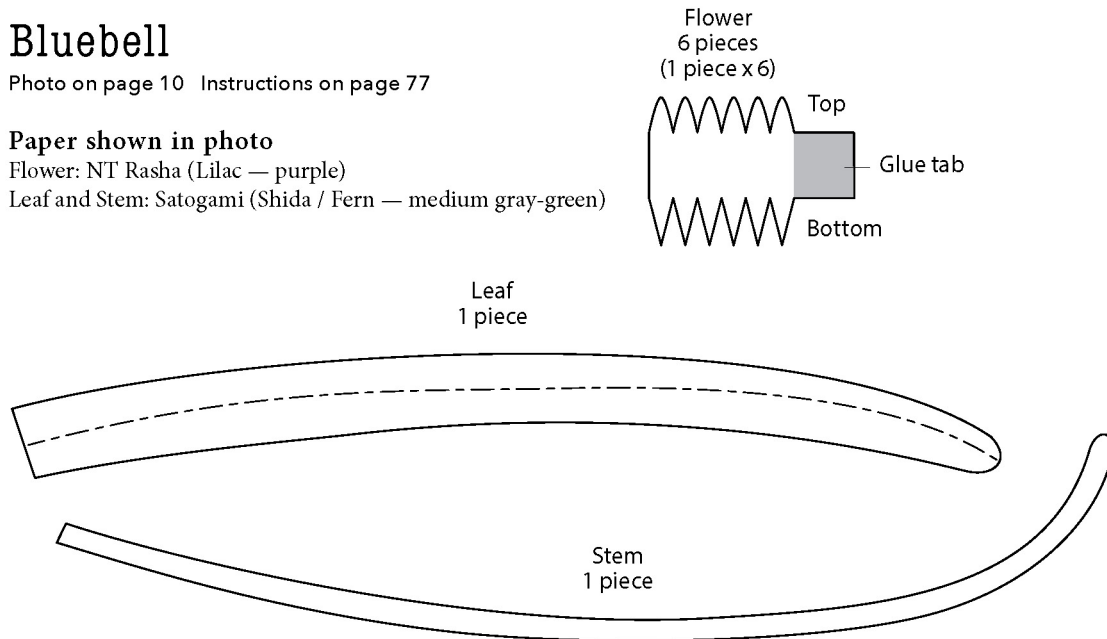

Chamomile

Photo on page 11 Instructions on page 78

Paper shown in photo

Flower Petal: Mermaid (Natural — off white)
 Flower Center: Canson Mi Teintes (400 — yellow)
 Leaf and Stem: Satogami (Uri / Gourd — light green)

Emboss line -----
 Line to cut later - - - - -
 Dashed fold line (valley fold) - - - - -
 Dotted fold line (mountain fold, align pattern to crease)

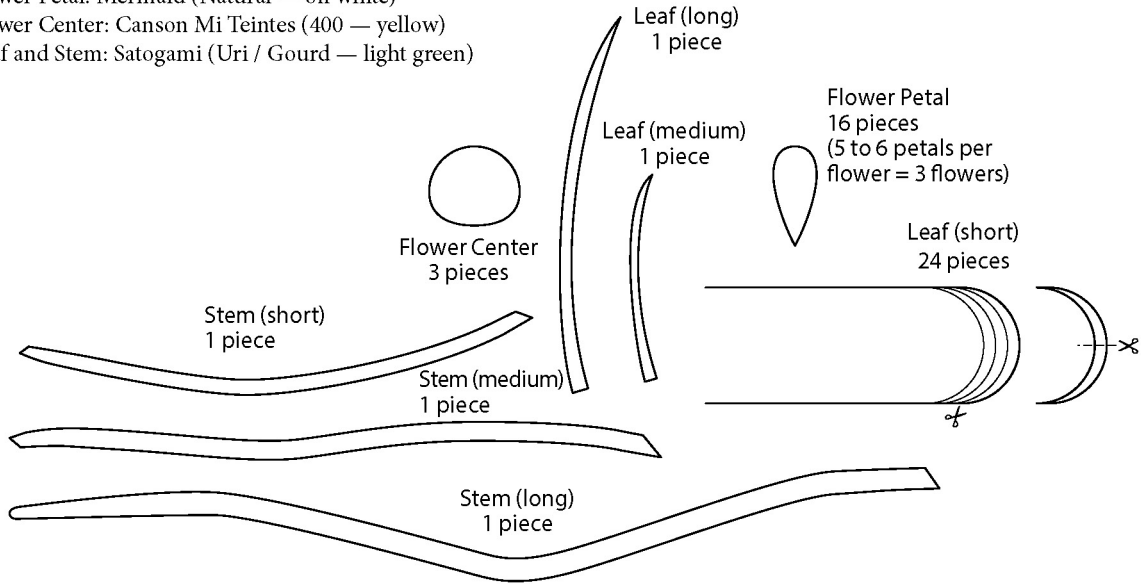

Sweet Violet

Photo on page 12 Instructions on page 79

Paper shown in photo

Flower Petal: Satogami (Bellflower — medium purple, Iris — deep purple)
 Flower Vein: Satogami (Silk — light purple)
 Leaf and Stem: Satogami (Shida / Fern — medium gray-green)

Top Flower Petal 3 pieces (1 piece x 3)

Flower Vein 9 pieces (3 pieces x 3)

Make a cut here

More than 1.18 in (3 cm)

0.55 in (1.4 cm)

Cut as narrowly as possible

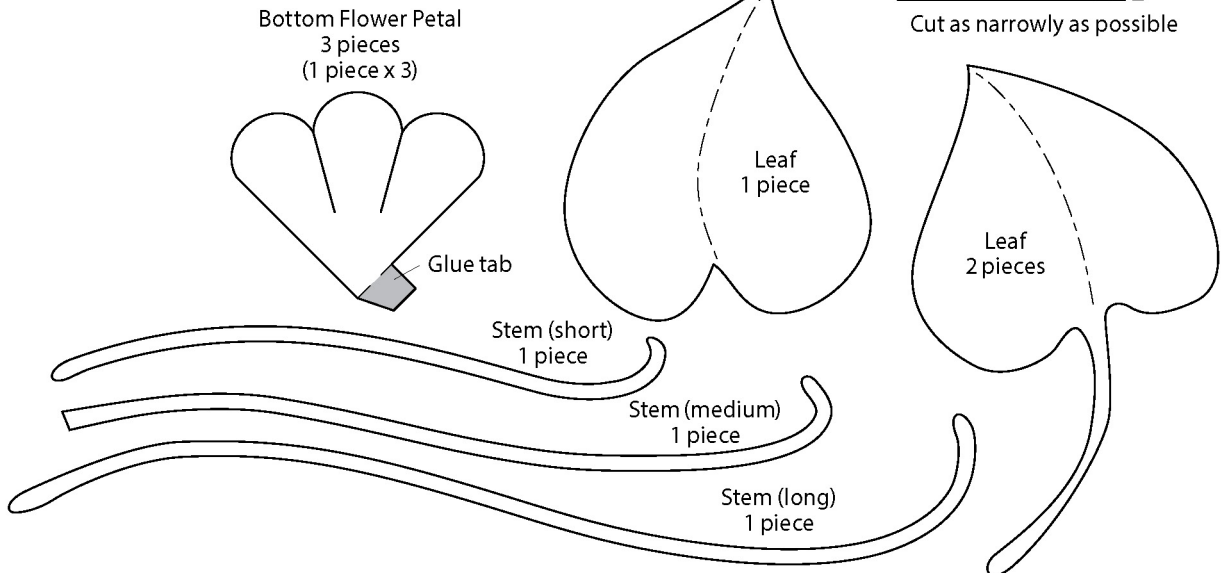

Vetch

Photo on pages 14-15 Instructions on page 82

Paper shown in photo

Flower Petal: Satogami (Ume — medium pink-purple,
Momiji — light red)

Leaf, Leaf Stem, Stem, Sepal, Pod, Pod Sepal and Tendril:
Satogami (Uri / Gourd — light green)

Emboss line -----
Line to cut later - - - - -
Dashed fold line (valley fold) — — —
Dotted fold line (mountain fold, align pattern to crease)

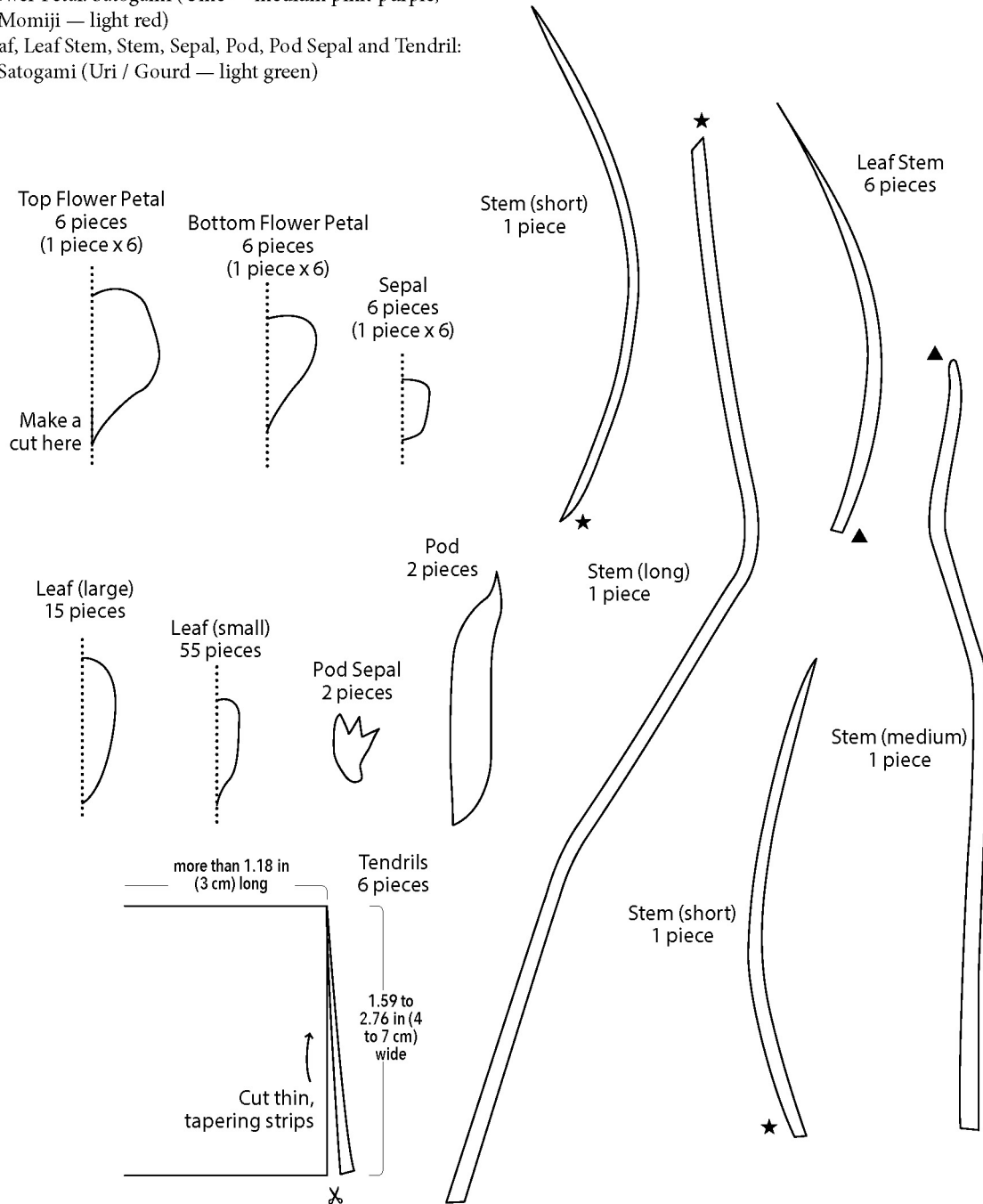

★ Adhere points with the star symbols together. ▲ Adhere points with the triangle symbols together.

Celandine

Photo on page 13 Instructions on page 80

Paper shown in photo

Flower Petal, Flower Base: Satogami (Yamabuki — golden yellow)

Sepal: Satogami (Uri / Gourd — light green)

Leaf, Stem: NT Rasha (drab green)

Emboss line -----
 Line to cut later - - - - -
 Dashed fold line (valley fold) — — —
 Dotted fold line (mountain fold, align pattern to crease)

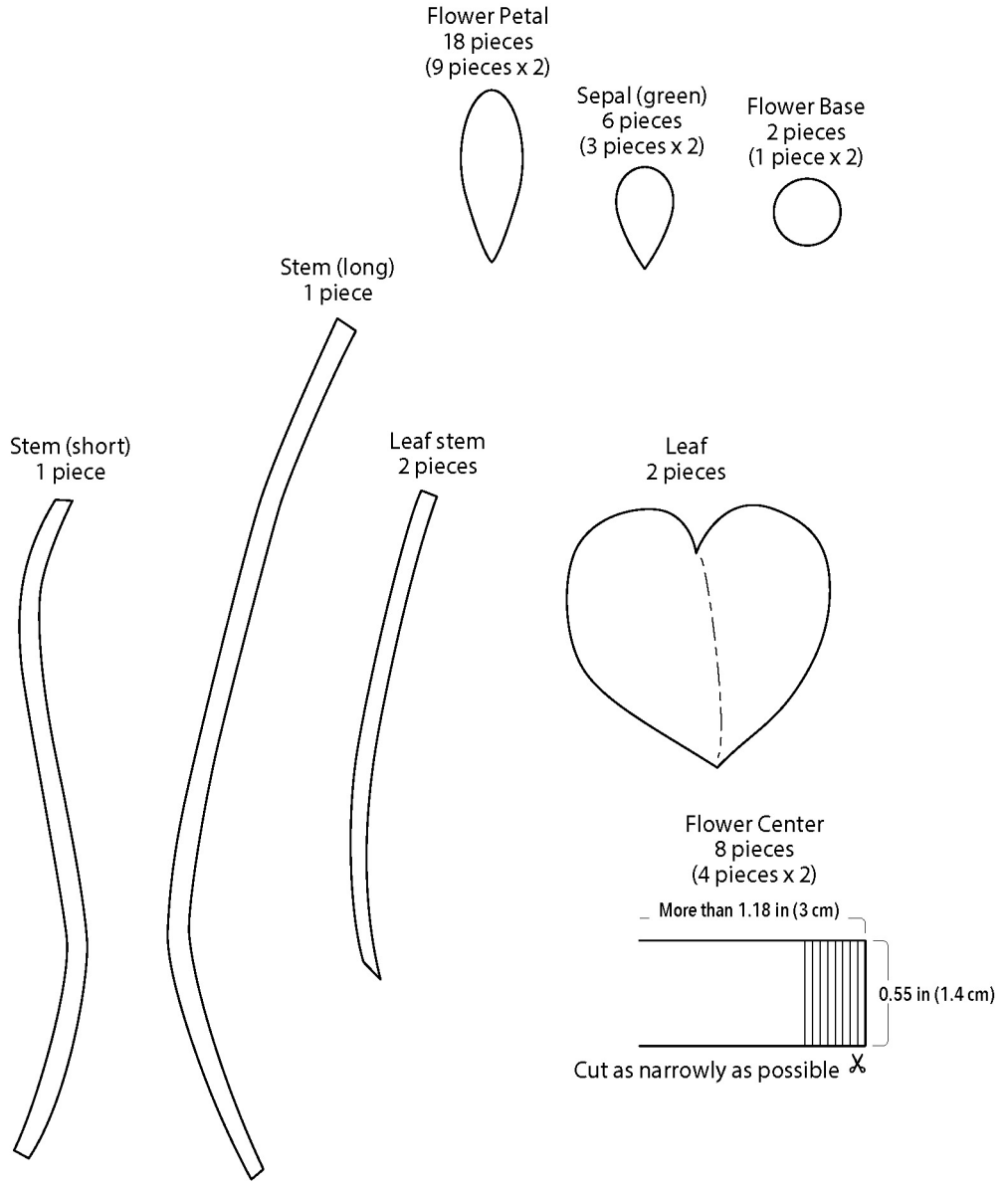

Lily of the Valley

Photo on page 18 Instructions on page 81

Paper shown in photo

Flower: Mermaid (Natural — off white)

Leaf: Satogami (Sugi / Pine — forest green), NT Rasha
(Shinbashi — dull green)

Emboss line -----
Line to cut later -----
Dashed fold line (valley fold) - - - - -
Dotted fold line (mountain fold, align pattern to crease)

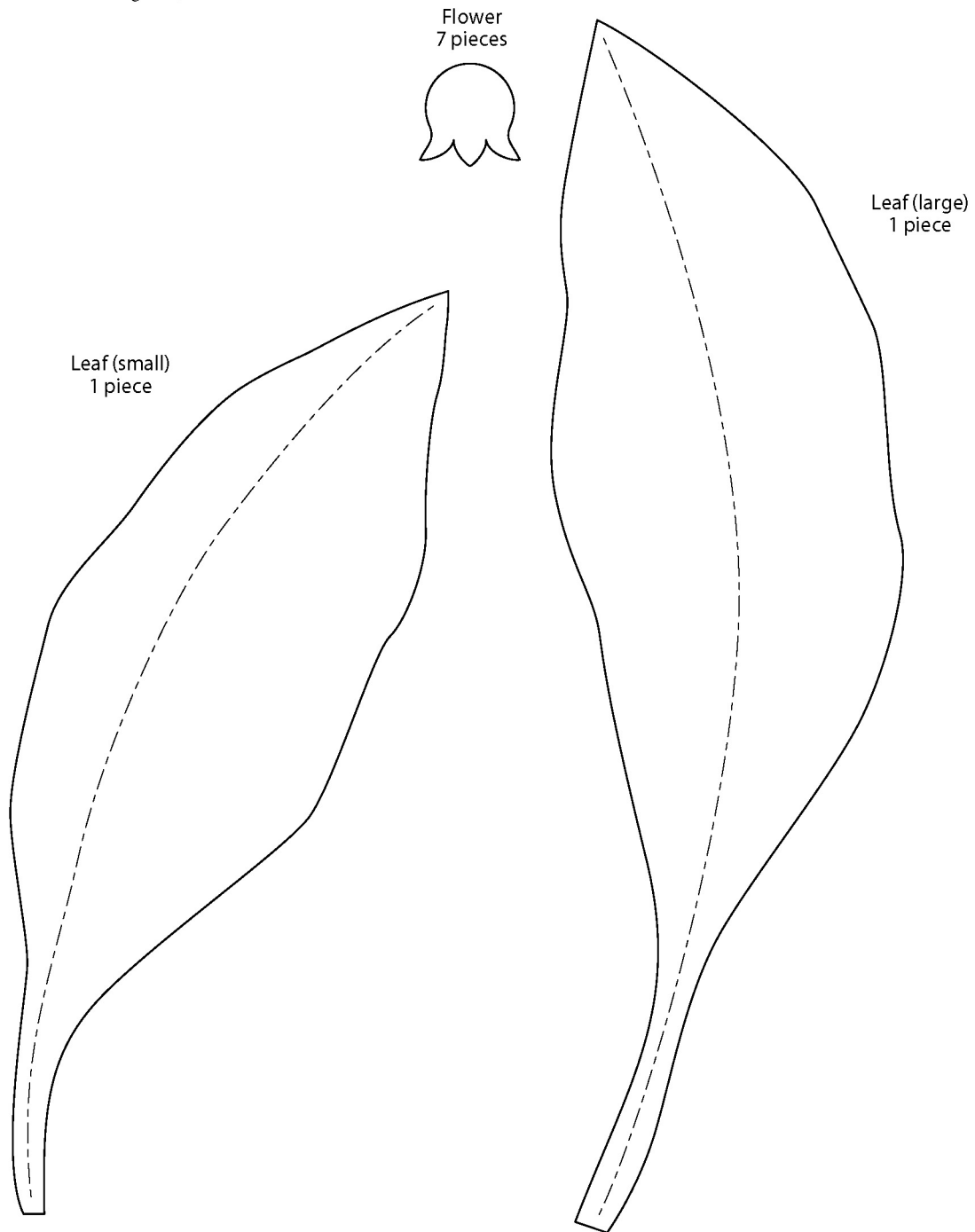

Daisy

Photo on page 16 Instructions on page 83

Paper shown in photo

Flower Petal, Flower Base: Mermaid (Natural — off white)

Flower Center: Satogami (Yamabuki — golden yellow)

Leaf, Stem: Satogami (Shida / Fern — medium gray-green)

Emboss line -----
 Line to cut later - - - - -
 Dashed fold line (valley fold) - - - - -
 Dotted fold line (mountain fold, align pattern to crease)

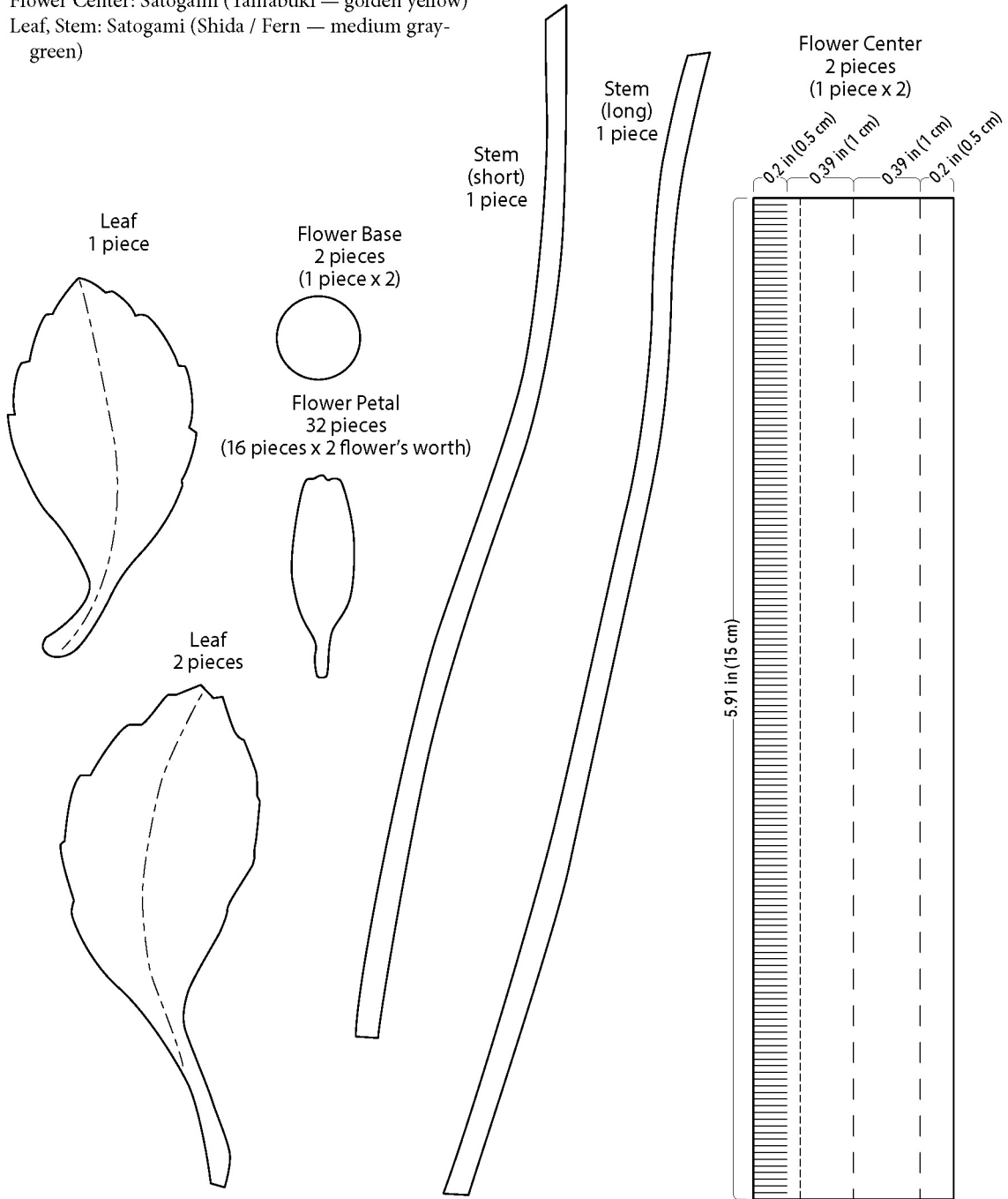

Columbine

Photo on page 19 Instructions on page 84

Emboss line -----
 Line to cut later -----
 Dashed fold line (valley fold) - - - - -
 Dotted fold line (mountain fold, align pattern to crease)

Paper shown in photo

Flower Petal, Flower Base: Mermaid (Lilac — light purple, Natural — off white), Tant (L-72 — medium-light purple)

Flower Center: Tant (Y-13 — pale yellow)

Leaf: Satogami (Sugi / Pine — forest green)

Stem: Satogami (Wara — straw)

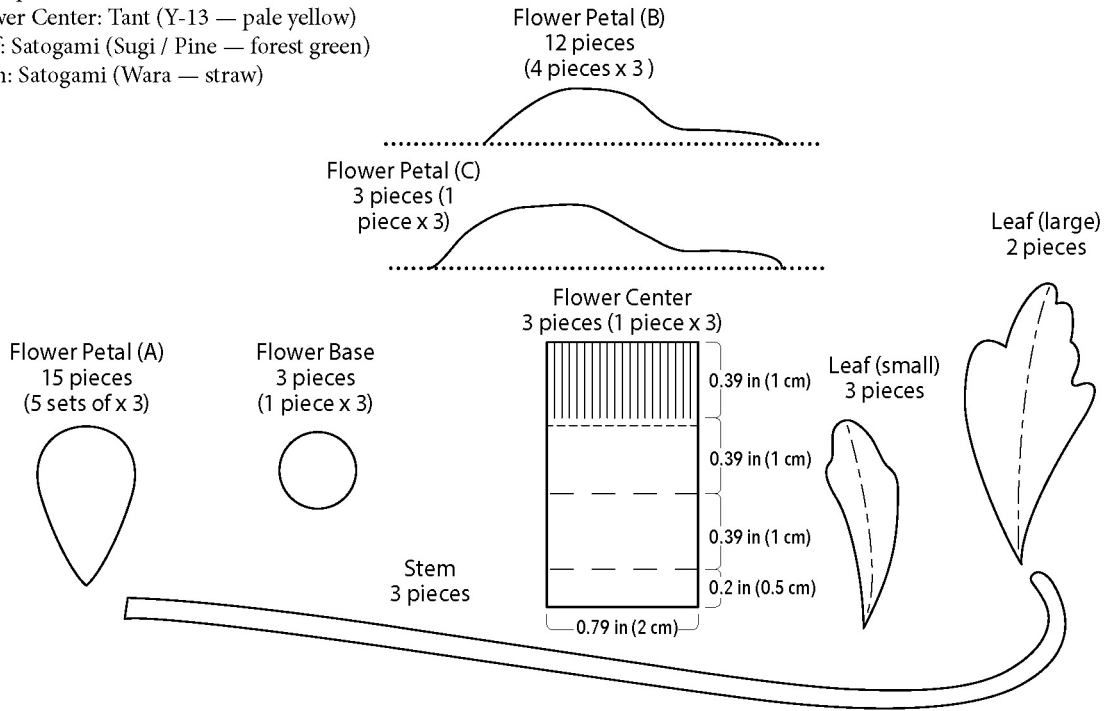

Garlic Mustard

Photo on page 20 Instructions on page 85

Paper shown in photo

Flower: Tant (0-61)

Leaf, Stem: Satogami (Uri / Gourd — light green)

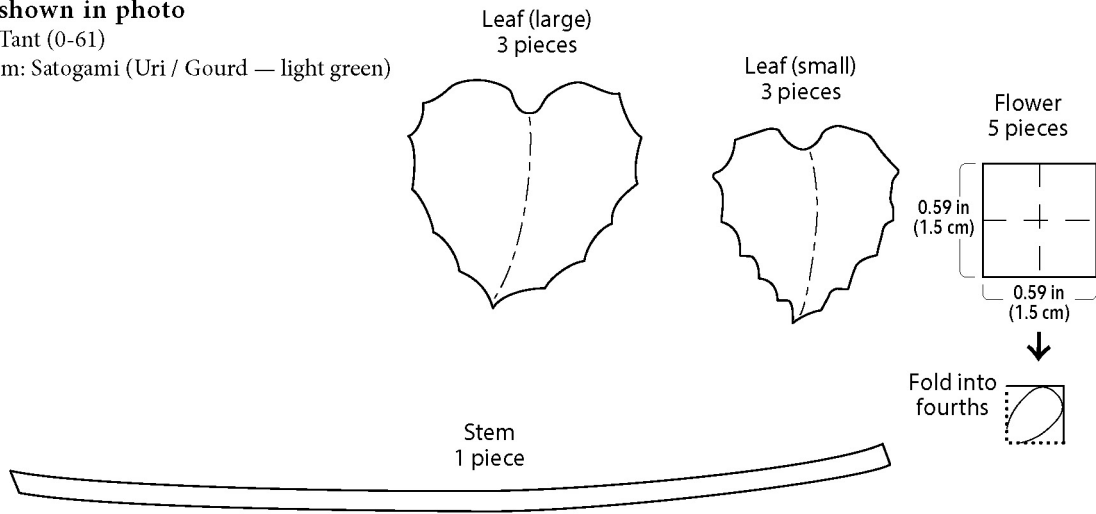

Blue Woodruff

Photo on page 21 Instructions on page 85

Paper shown in photo

Flower: Tant (L-71 — medium purple)

Leaf: Satogami (Take / Bamboo — medium green)

Emboss line -----
 Line to cut later - - - - -
 Dashed fold line (valley fold) - - - - -
 Dotted fold line (mountain fold, align pattern to crease)

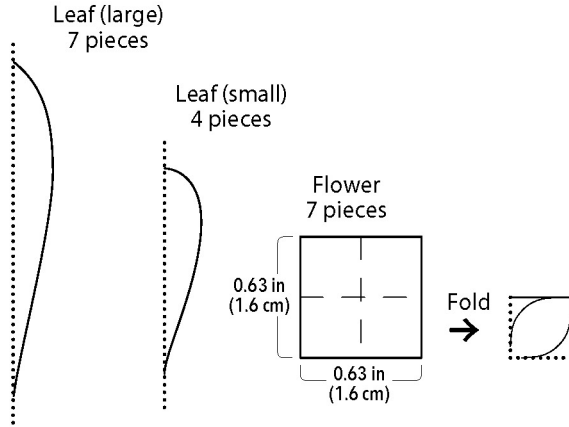

Sea Thrift

Photo on page 22 Instructions on page 86

Paper shown in photo

Flower Petal: Tant (L-73 — light red-purple)

Sepal: Satogami (Uri / Gourd — light green)

Leaf, Stem: Satogami (Shida / Fern — medium gray-green)

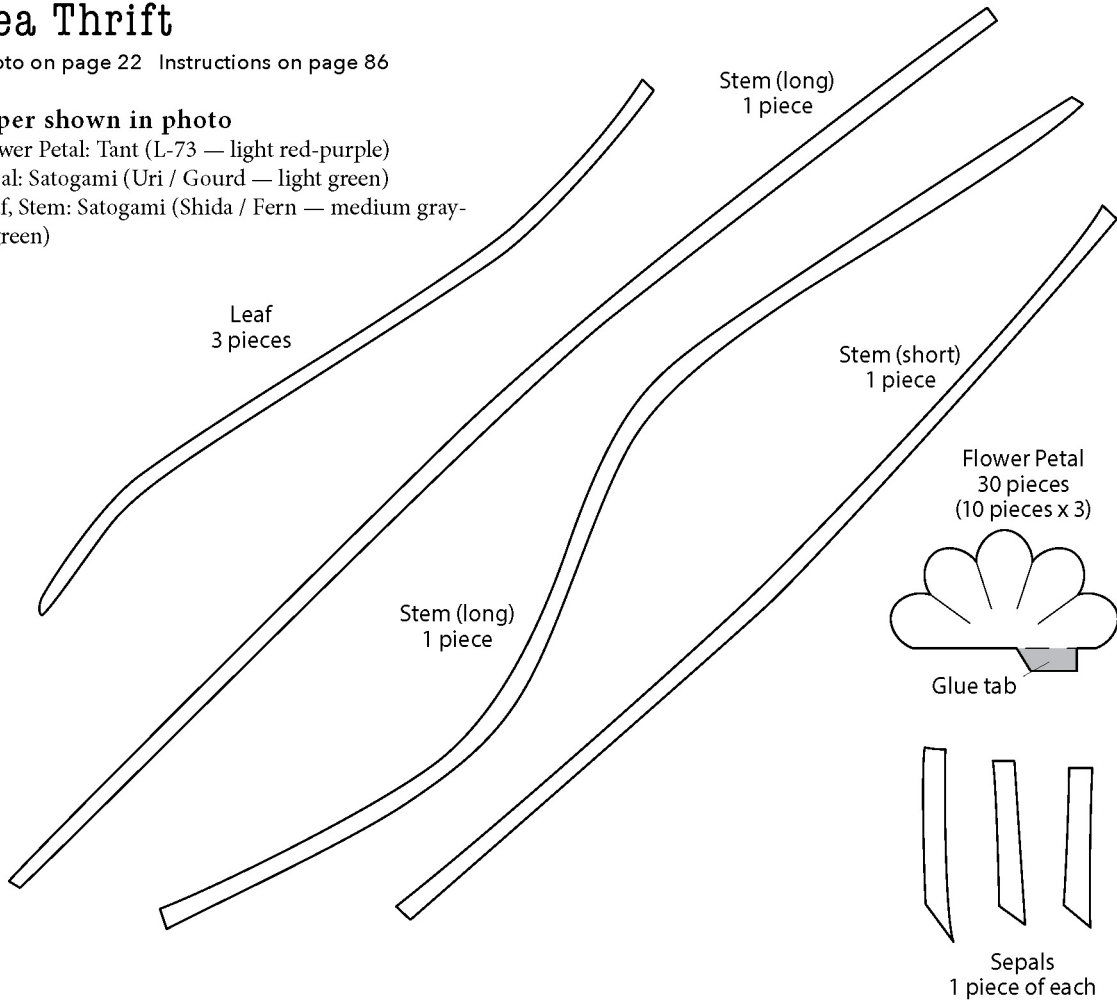

Climbing Rose

Photo on pages 24-25 Instructions on page 88

Emboss line -----
 Line to cut later - - - - -
 Dashed fold line (valley fold) — — —
 Dotted fold line (mountain fold, align pattern to crease)

Paper shown in photo

Flower Petal, Flower Base: Tant (L-73 — light red-purple,
 G50 — light pink), Satogami (White)
 Bud: Satogami (Shida / Fern — medium gray-green)
 Leaf: Satogami (Shida / Fern — medium gray-green, Sugi
 / Pine — forest green)
 Stem: Satogami (Shida / Fern — medium gray-green)
 Tendril: Satogami (Tobi — medium beige)

Flower Base
 9 pieces
 (1 piece x 9)

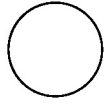

Flower Petal
 107 pieces
 (13 pieces x 6, 8 pieces x 3)

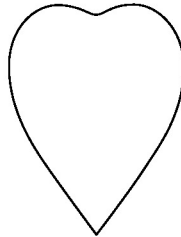

Leaf
 22 pieces

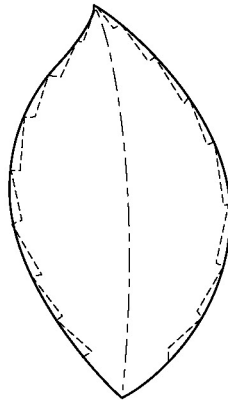

How to cut the serrated edges

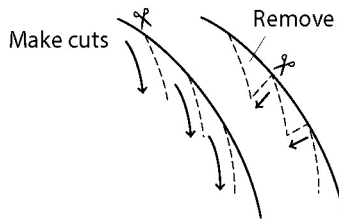

Cut the serrated edges after cutting out the leaves. You don't have to follow the pattern exactly to cut the edges.

Bud
 3 pieces



Stem
 7 pieces



Tendril
 4 pieces

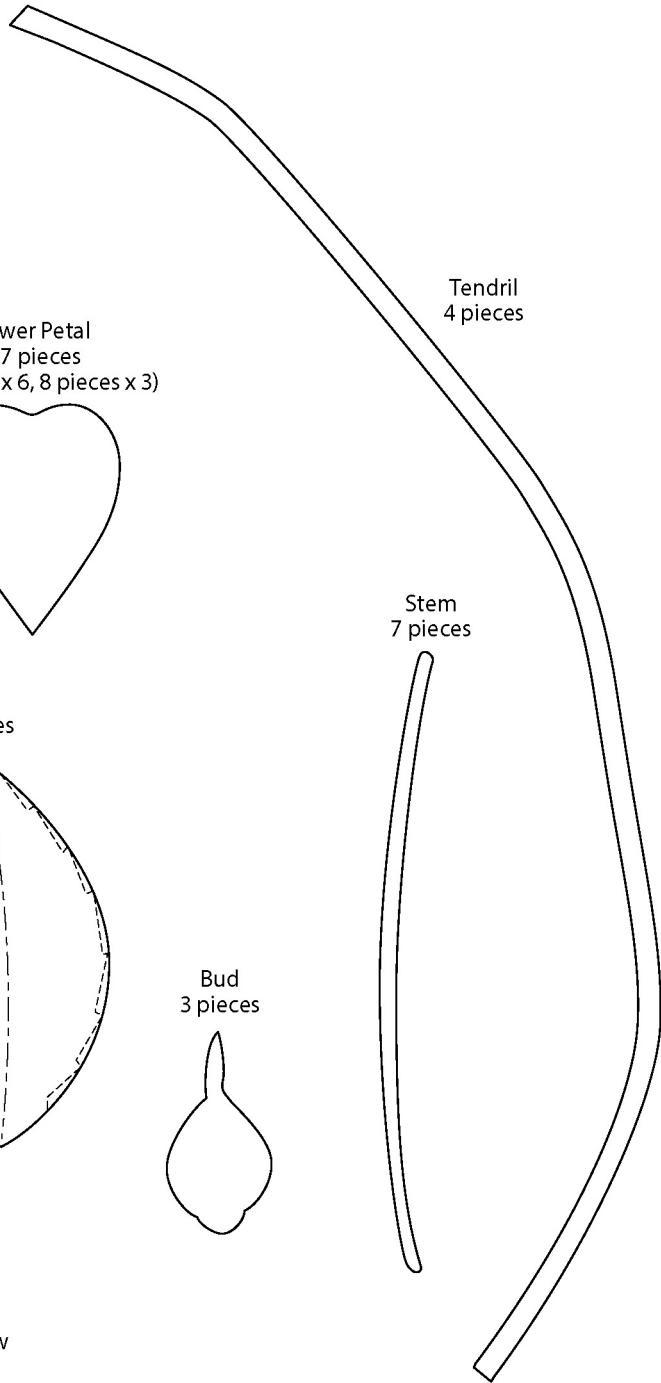

Buttercup

Photo on page 26 Instructions on page 89

Paper shown in photo

Flower Petal, Flower Base, Flower Center: Satogami

(Yamabuki — golden yellow)

Leaf, Bud: NT Rasha (Nibubiwa — gray-green)

Stem: Tant (G-63 — light gray-green)

Emboss line -----
 Line to cut later -----
 Dashed fold line (valley fold) - - - - -
 Dotted fold line (mountain fold, align pattern to crease)

Flower Petal
 10 pieces
 (5 pieces x 2)



Flower Base
 2 pieces
 (1 piece x 2)



Flower Center
 2 pieces
 (1 piece x 2)

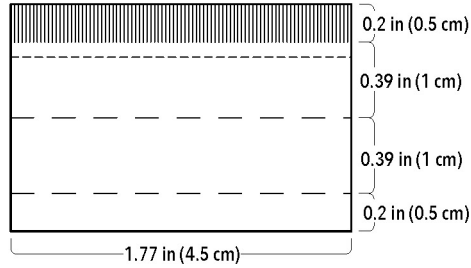

Stem (long)
 1 piece



Stem (medium)
 1 piece



Stem (short)
 1 piece



Leaf (large)
 3 pieces



Bud
 1 piece



Leaf (small)
 3 pieces



Chive

Photo on page 27 Instructions on page 89

Paper shown in photo

Flower: Gokanshi (Peach)

Leaf, Stem: Satogami (Shida / Fern — medium gray-green)

Emboss line -----
Line to cut later - - - - -
Dashed fold line (valley fold) - - - - -
Dotted fold line (mountain fold, align pattern to crease)

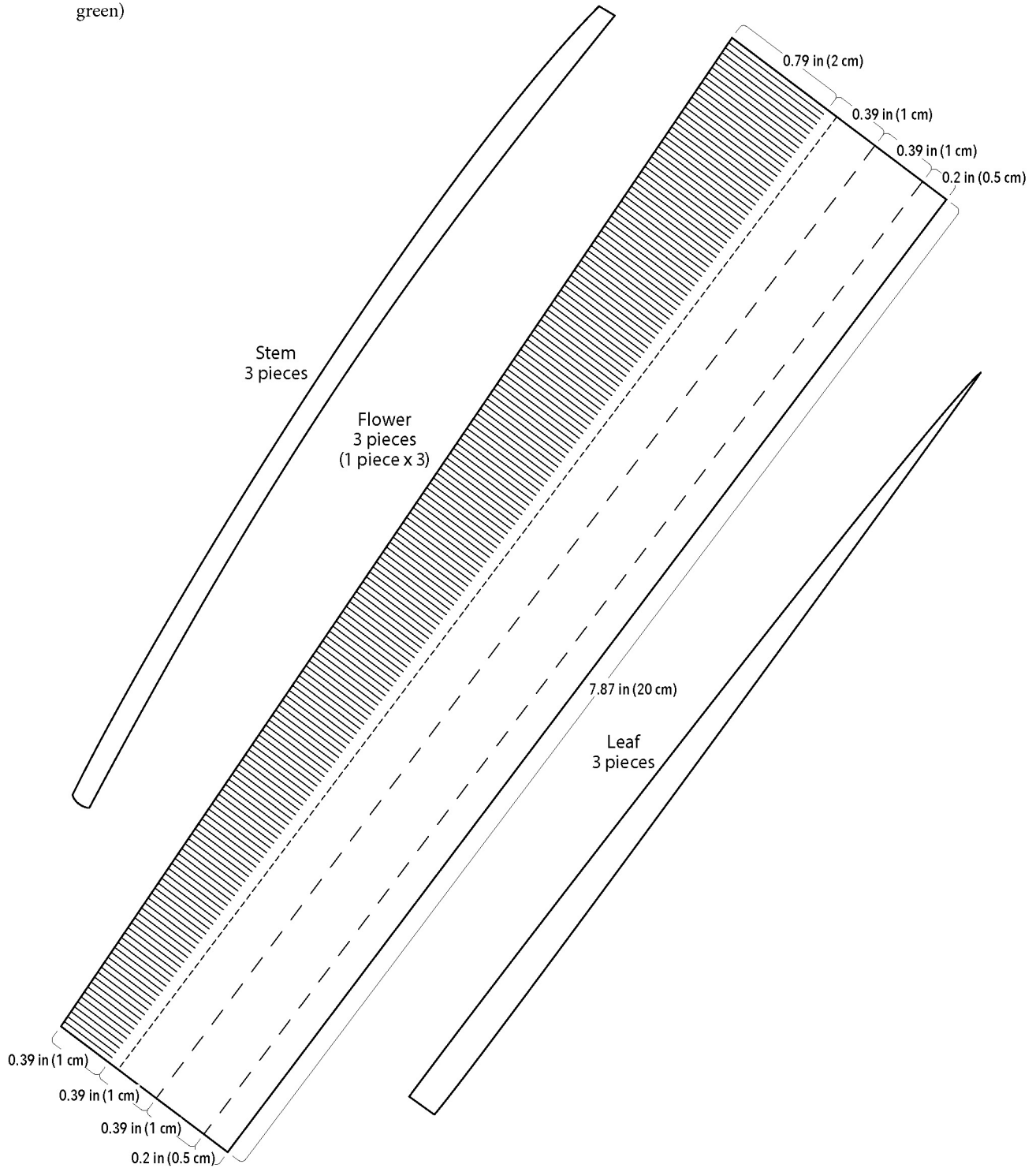

Red Clover

Photo on page 28 Instructions on page 92

Paper shown in photo

Flower Petal: Satogami (Ume — medium pink-purple,
Momiji — light red)

Leaf: Canson Mi Teintes (480 — light green)

Stem: Tant (G-63 — light gray-green)

Emboss line -----
Line to cut later -----
Dashed fold line (valley fold) - - - - -
Dotted fold line (mountain fold, align pattern to crease)

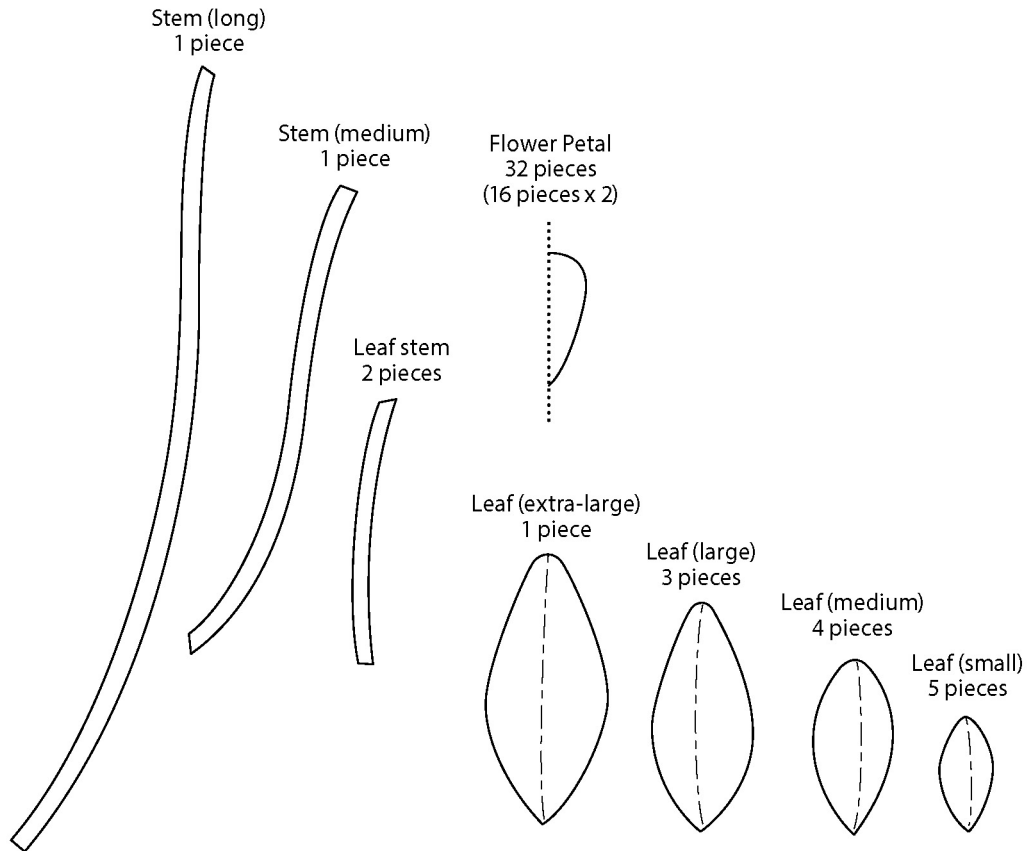

Lily

Photo on page 30 Instructions on page 90

Paper shown in photo

Flower: Mermaid (Natural — off white)
 Flower Center: Satogami (Kibi — light gray-green)
 Anther: Tant (L-57 — pale yellow)
 Leaf, Stem: Satogami (Sugi / Pine — forest green)

Emboss line -----
 Line to cut later - - - - -
 Dashed fold line (valley fold) - - - - -
 Dotted fold line (mountain fold, align pattern to crease)

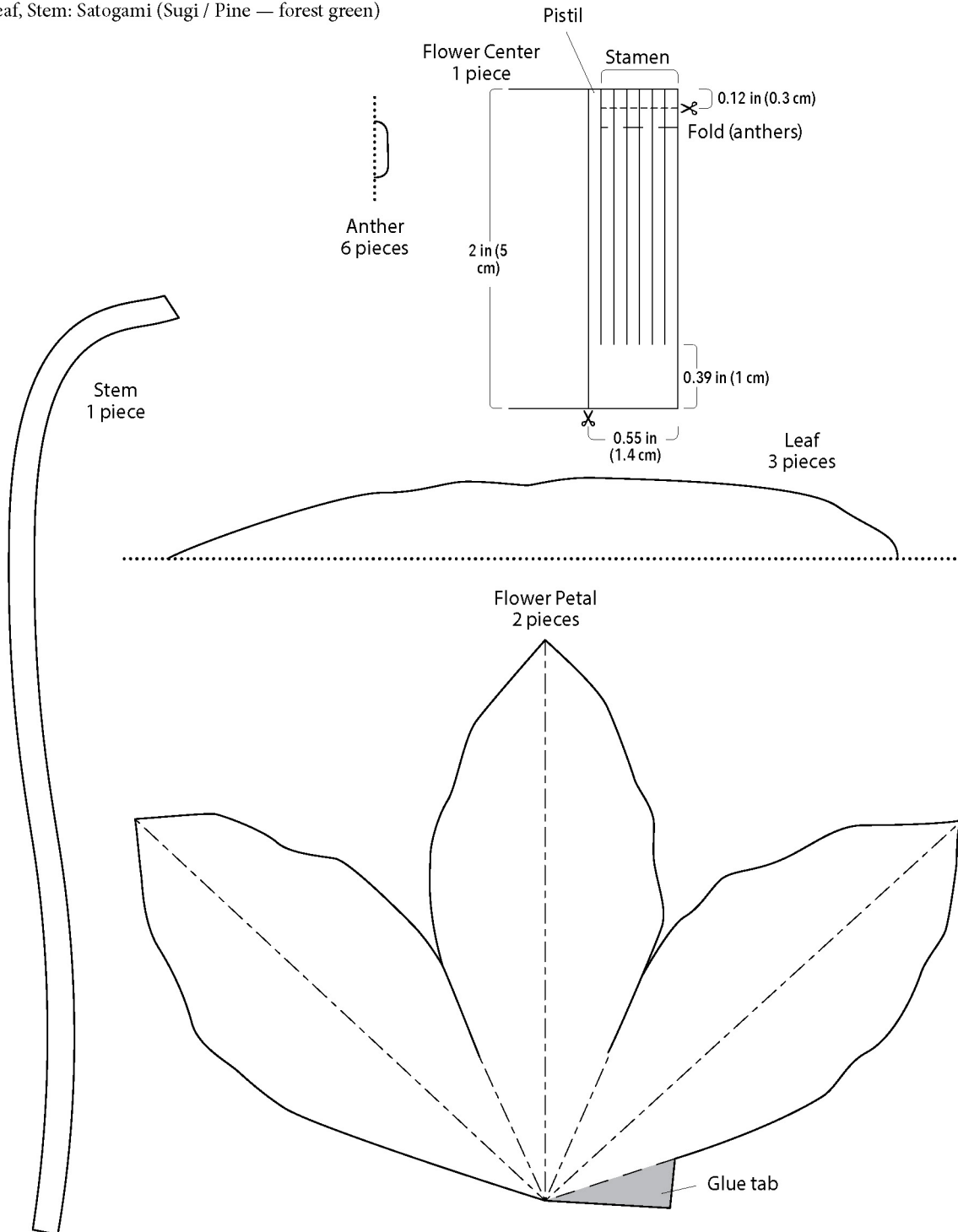

Red Currant

Photo on page 31 Instructions on page 91

Paper shown in photo

Berry: Mermaid (Karabeni — dark red), Satogami
 (Momiji — light red, Anzu — light orange)
 Leaf: NT Rasha (Nibubiwa — light gray)
 Stem: Satogami (Kozo — light brown)

Emboss line -----
 Line to cut later -----
 Dashed fold line (valley fold) - - - - -
 Dotted fold line (mountain fold, align pattern to crease)

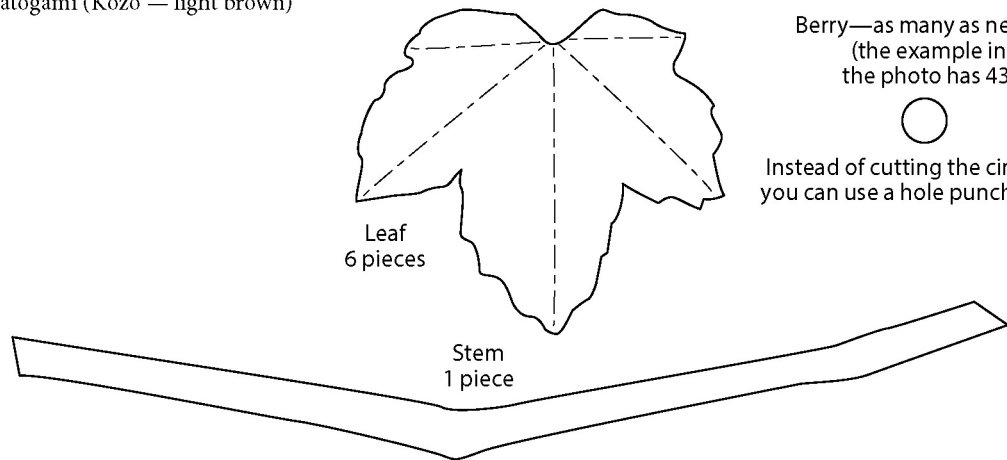

Rose

Photo on page 32 Instructions on page 94

Paper shown in photo

Flower Petal, Flower Center, Flower Base:
 Tant (G-52 — grayish pink), Canson Mi-
 Teintes (352 — orchid)
 Leaf, Stem, Thorn: Tant (D-61 — medium
 leaf green), NT Rasha (olive)

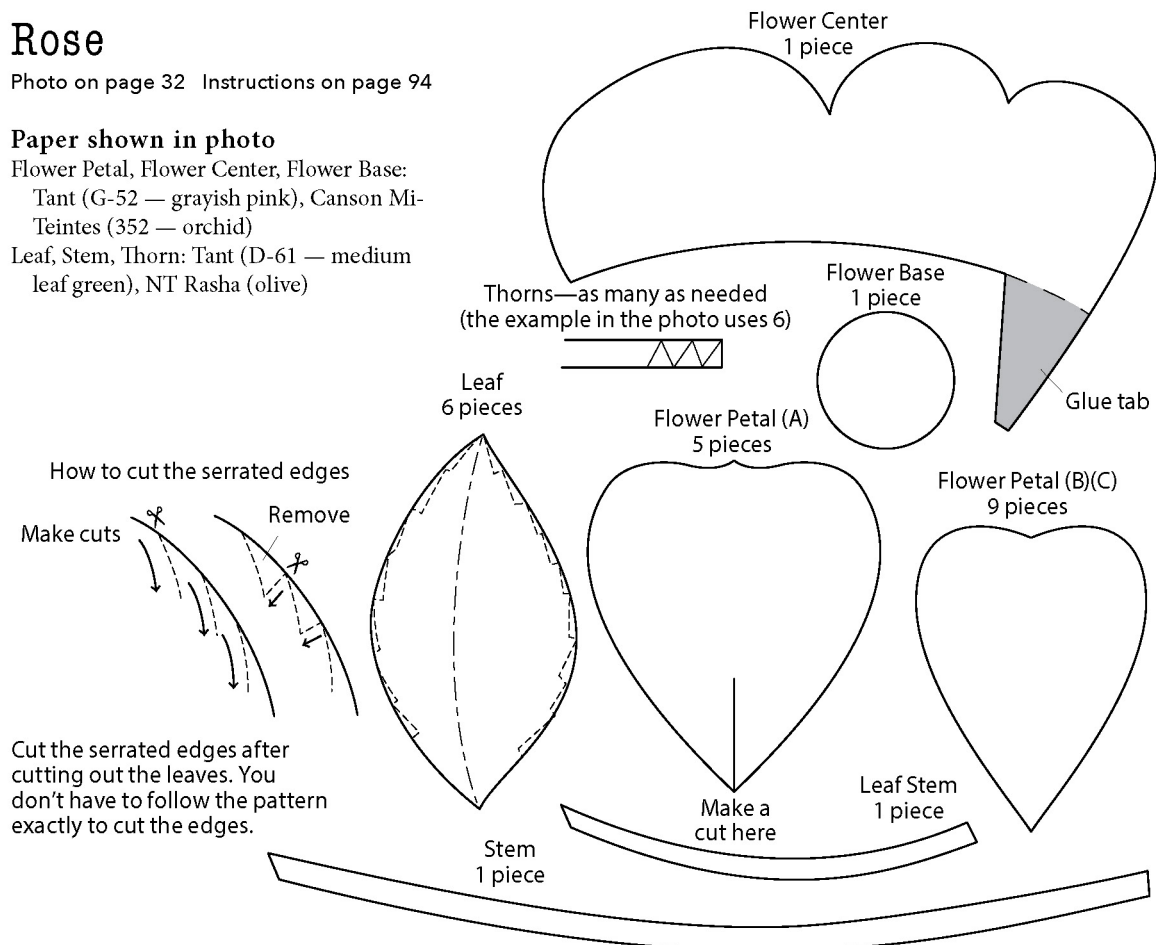

Lavender

Photo on page 33 Instructions on page 95

Paper shown in photo

Flower: Satogami (Ayame — medium purple, Kikyo — light purple)

Emboss line -----
Line to cut later -----
Dashed fold line (valley fold) - - - - -
Dotted fold line (mountain fold, align pattern to crease)

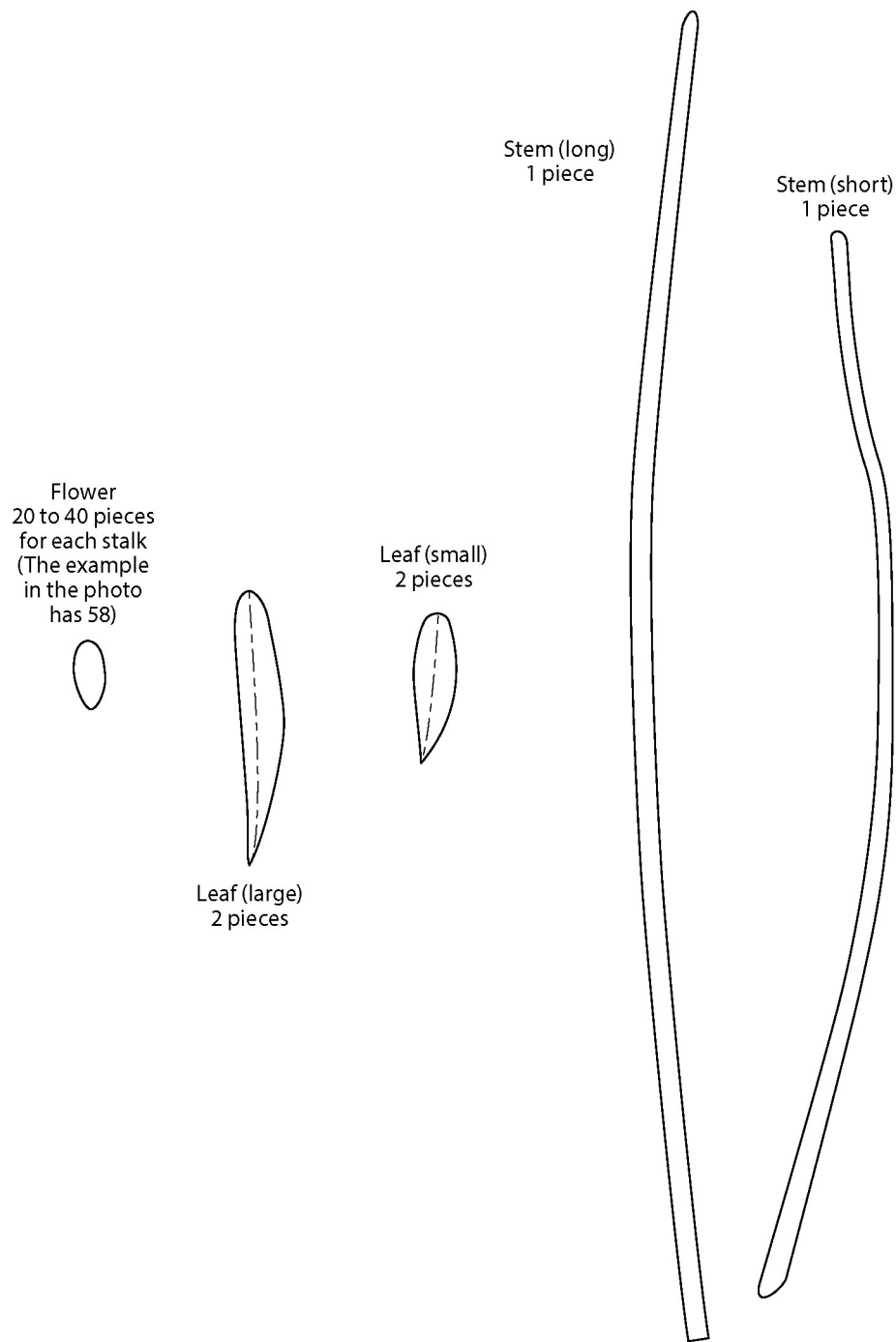

Poppy

Photo on page 34 Instructions on page 93

Paper shown in photo

Flower Petal, Flower Base: Tant (D-54 — dark orange,
D-55 — orange)

Flower Center: Tant (L-57 — ecru, R-3 — medium gray)

Bud, Leaf, Stem: Tant (D-61 — medium leaf green)

Emboss line -----
Line to cut later -----
Dashed fold line (valley fold) - - - - -
Dotted fold line (mountain fold, align pattern to crease)

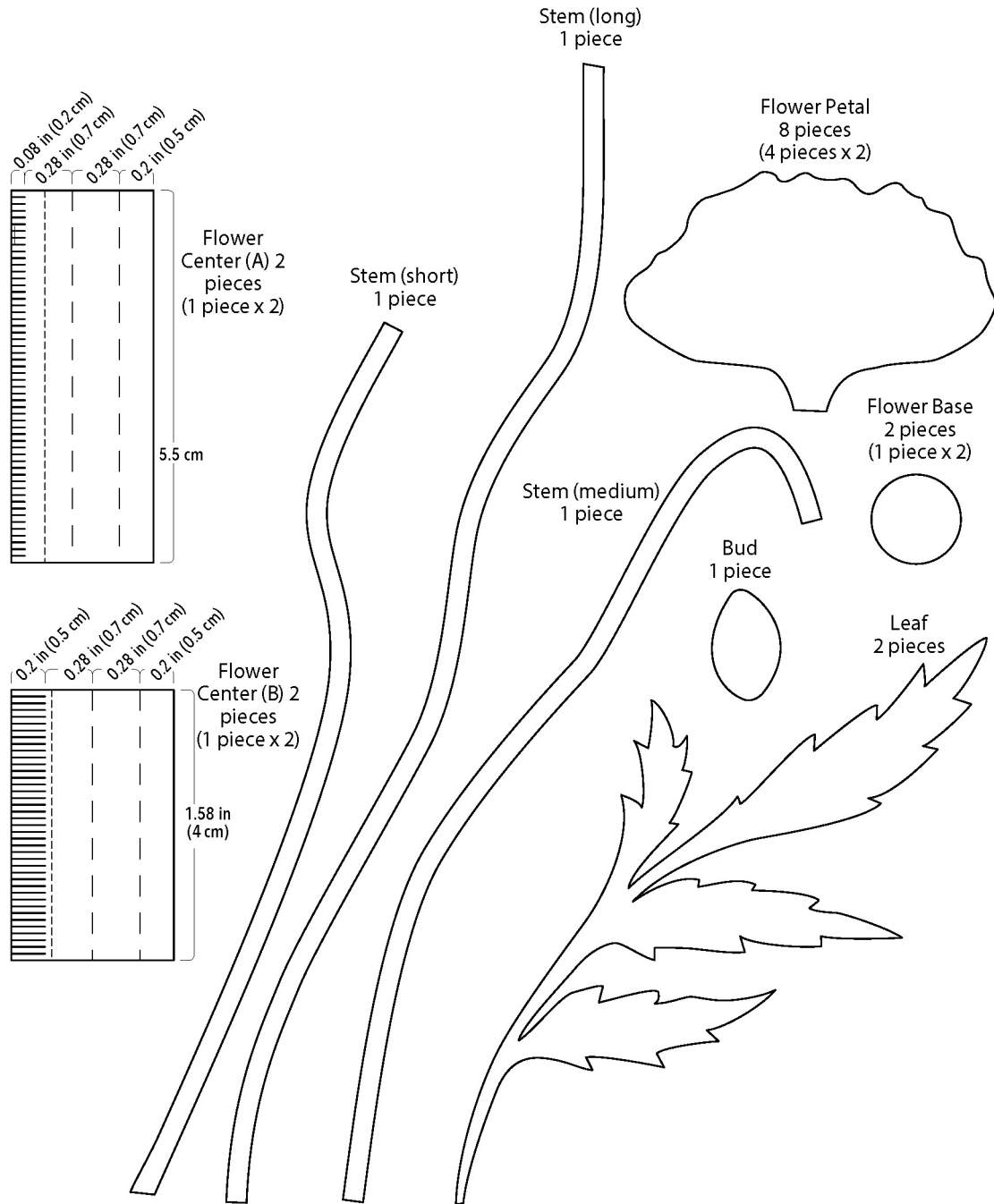

Dog Rose

Photo on pages 36-37 Instructions on page 96

Paper shown in photo

Flower Petal, Flower Base: Satogami (Sakura — light pink)

Flower Center: Tant (E-50 — light gray)

Leaf, Stem: Satogami (Wara — straw)

Emboss line -----
 Line to cut later - - - - -
 Dashed fold line (valley fold) - - - - -
 Dotted fold line (mountain fold, align pattern to crease)

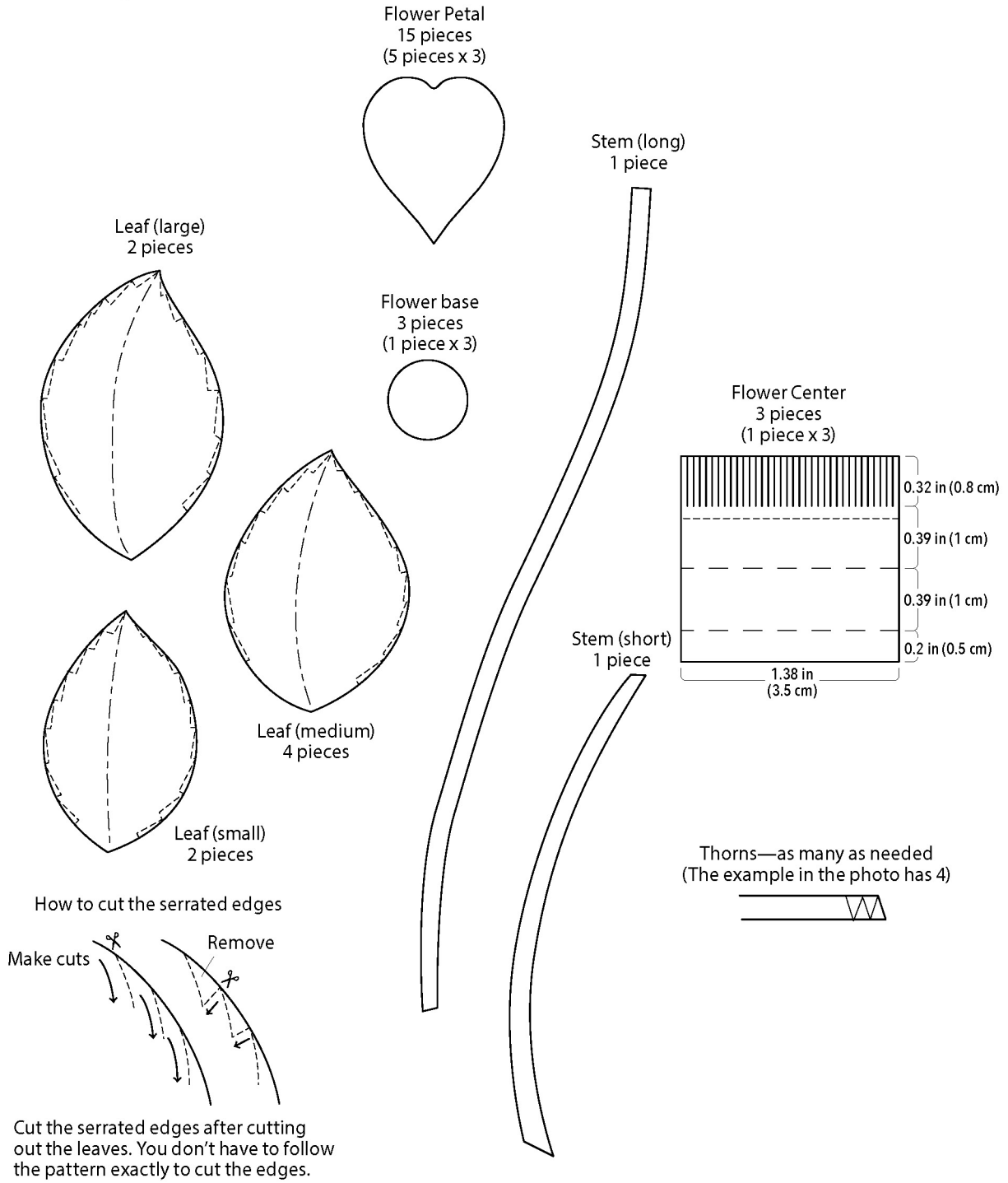

Common Mallow

Photo on pages 38-39 Instructions on page 97

Paper shown in photo

Flower Petal: Mermaid (Peach)
 Flower Center: Tant (E-50 — pale purple)
 Flower Vein: Satogami (Momiji — light red)
 Sepal, Leaf: Satogami (Uri / Gourd — light green)

Emboss line -----
 Line to cut later -----
 Dashed fold line (valley fold) - - - - -
 Dotted fold line (mountain fold, align pattern to crease)

Flower Petal
 20 pieces
 (5 pieces x 4)



Sepal
 4 pieces
 (1 piece x 4)

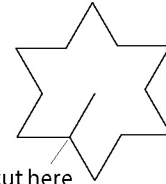

Flower Veins
 50 pieces
 (15 pieces x 4)

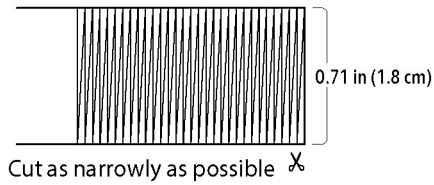

Leaf (large)
 2 pieces

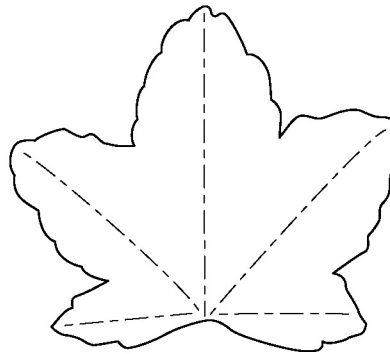

Flower Center
 4 pieces
 (1 piece x 4)

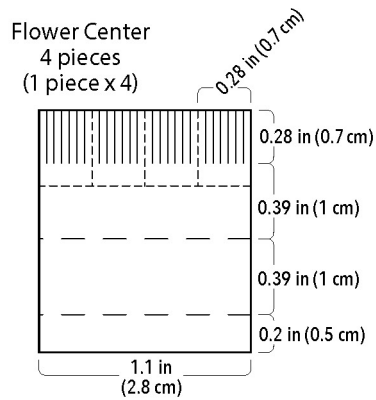

Leaf (small)
 4 pieces

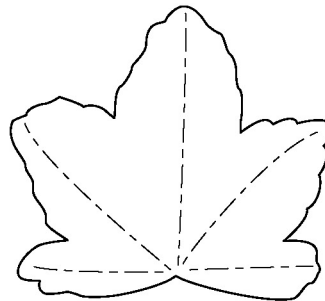

Globe Flower

Photo on page 40 Instructions on page 98

Paper shown in photo

Flower Petal, Flower Base: Canson Mi-Teintes (400 — canary)

Stem: Tant (G-63 — light gray-green)

Emboss line -----
 Line to cut later -----
 Dashed fold line (valley fold) - - - - -
 Dotted fold line (mountain fold, align pattern to crease)

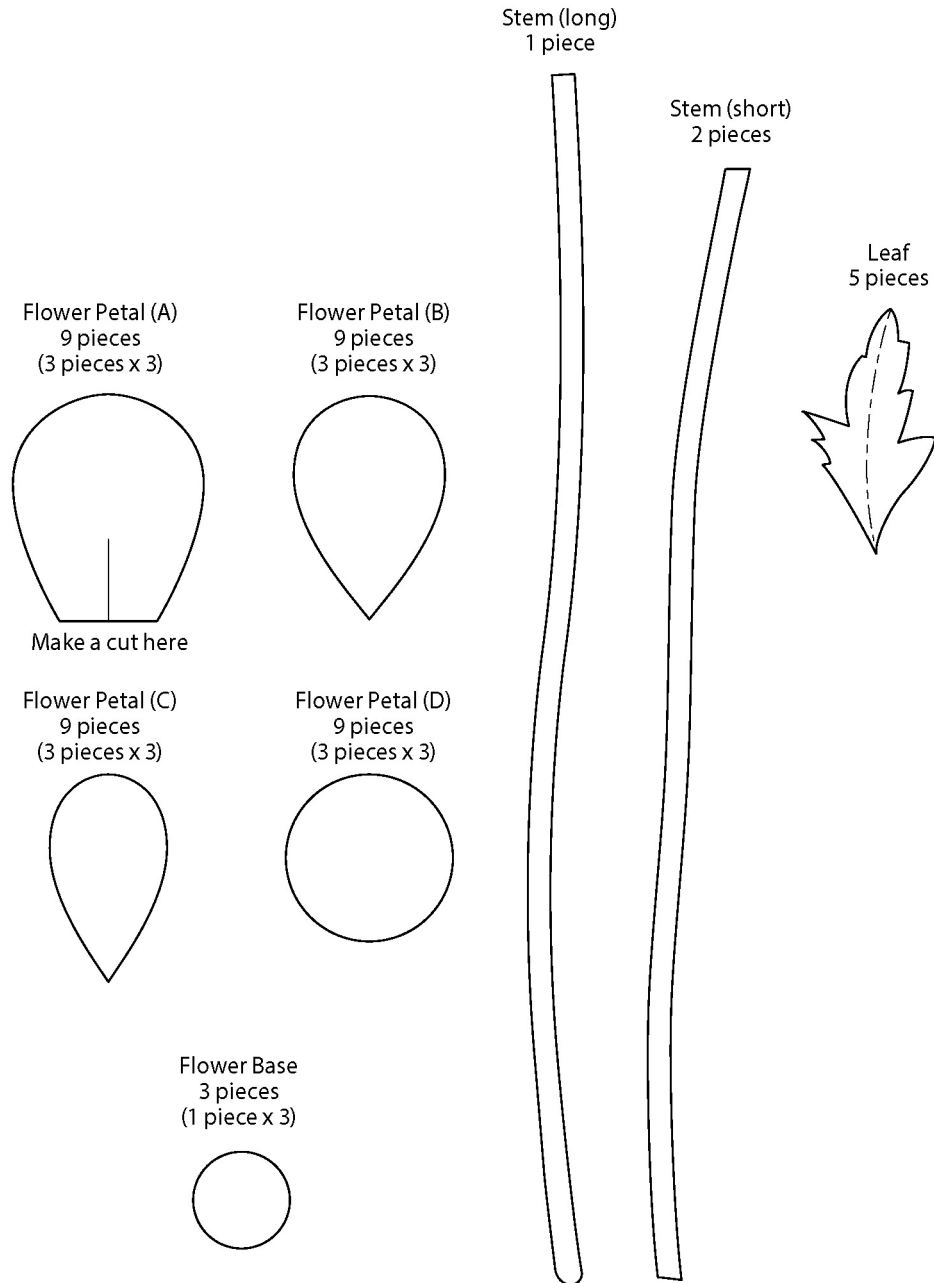

Forget-me-not

Photo on page 42 Instructions on page 99

Paper shown in photo

Flower: Satogami (Yanagi / Willow — light blue)
Flower Center: Satogami (Nanohana — pale lemon)
Bud, Leaf, Stem: Satogami (Take / Bamboo — blue-green)

Emboss line -----
Line to cut later -----
Dashed fold line (valley fold) - - - - -
Dotted fold line (mountain fold, align pattern to crease)

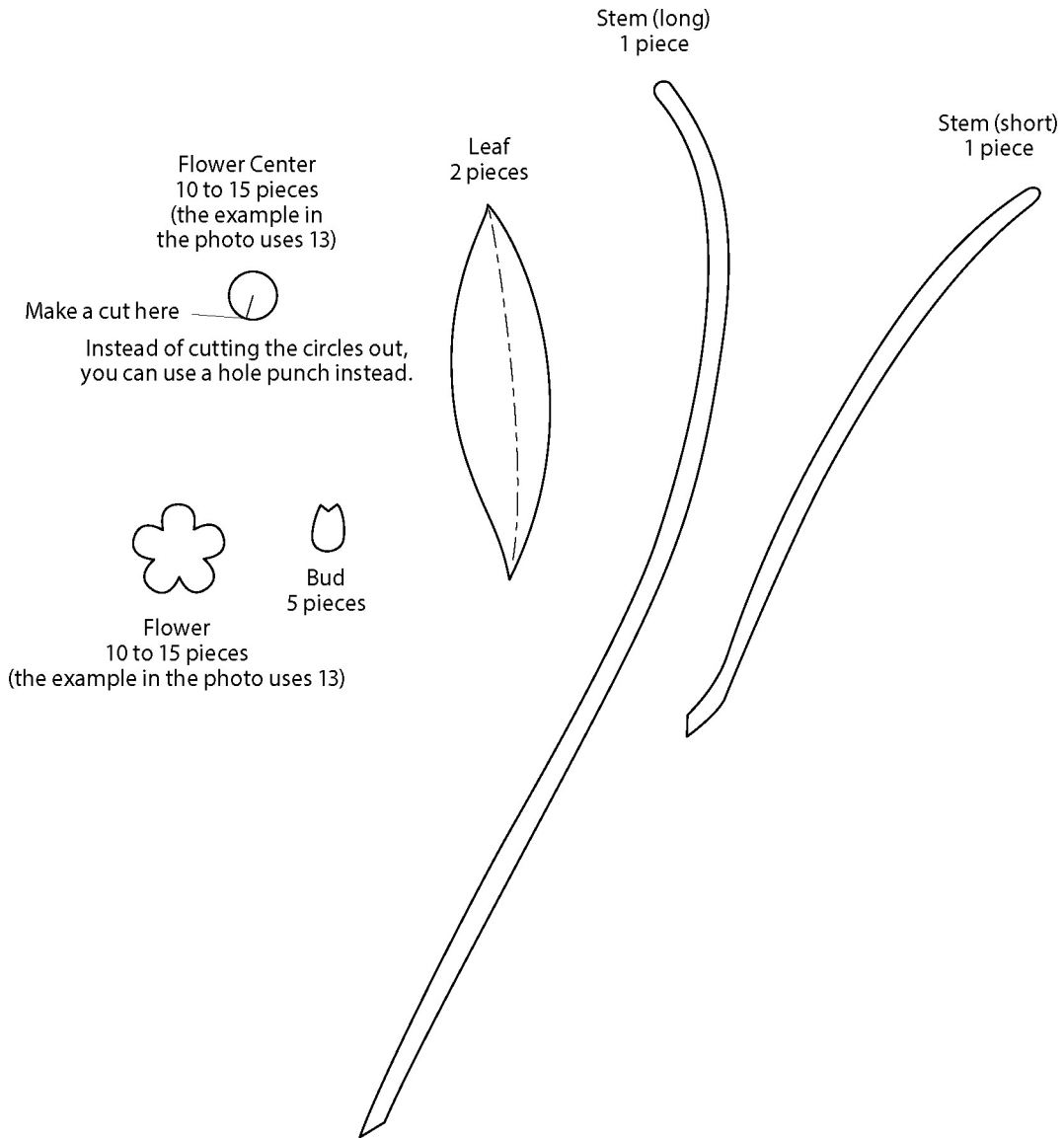

Edelweiss

Photo on page 43 Instructions on page 100

Paper shown in photo

Flower Petal, Flower Center, Flower Base: Mermaid (White)

Leaf: Satogami (Take / Bamboo — blue-green)

Emboss line -----
 Line to cut later -----
 Dashed fold line (valley fold) - - - - -
 Dotted fold line (mountain fold, align pattern to crease)

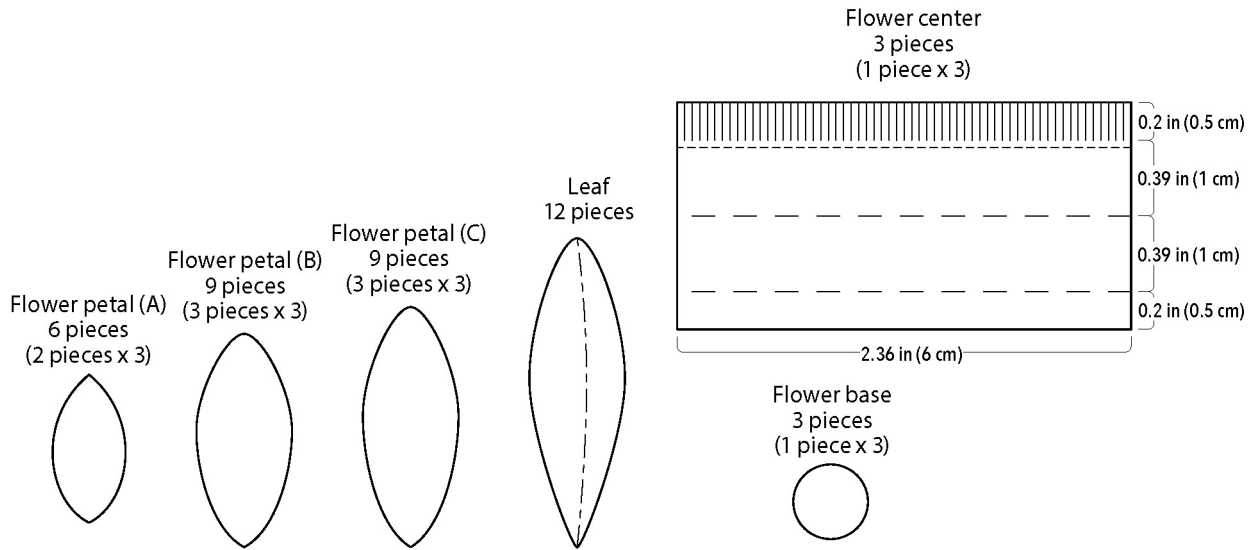

Blackberry

Photo on page 44 Instructions on page 101

Paper shown in photo

Berry, Berry Base: Mermaid (Koihanata — navy blue),
 NT Rasha (Ai — indigo blue), Satogami (Adzuki — red-dish-brown, Momiji — light red)

Leaf: Satogami (Take / Bamboo — blue-green)

Stem: (Susuki — medium leaf green)

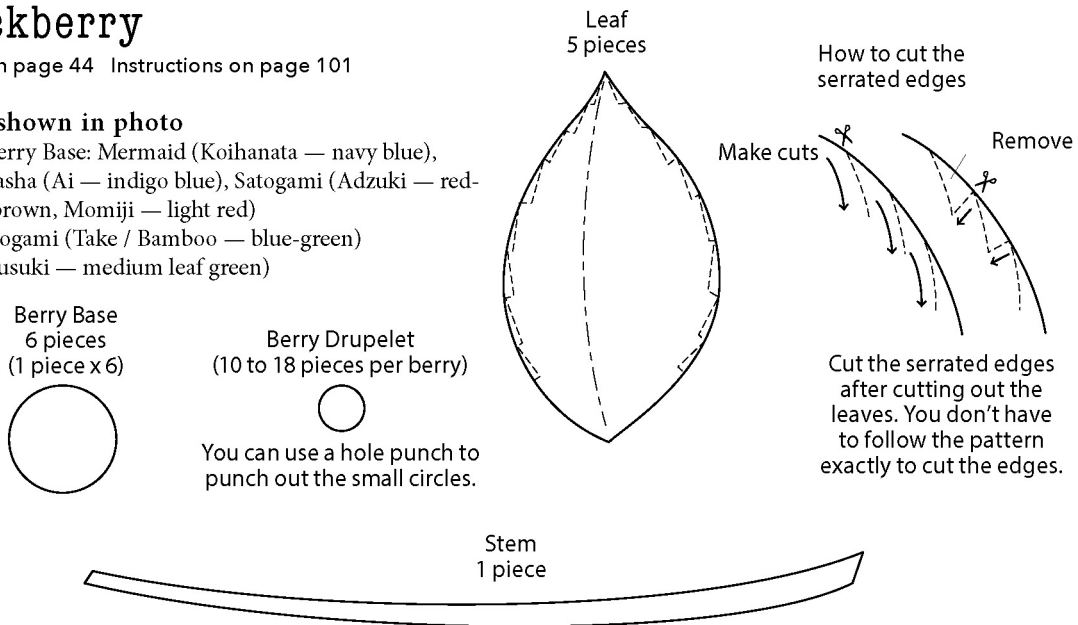

Pincushion Flower

Photo on page 46 Instructions on page 102

Emboss line -----
 Line to cut later - - - - -
 Dashed fold line (valley fold) - - - - -
 Dotted fold line (mountain fold, align pattern to crease)

Paper shown in photo

Flower Petal: Tant (L-72 (light purple), NT Rasha (dark purple)
 Flower Center: Tant (G-72 — light purple), NT Rasha (dark purple)
 Bud, Sepal: (Shida / Fern — medium gray-green)
 Leaf, Stem: Canson Mi-Teintes (480 — light green), Satogami
 (Matsu / Pine — forest green)

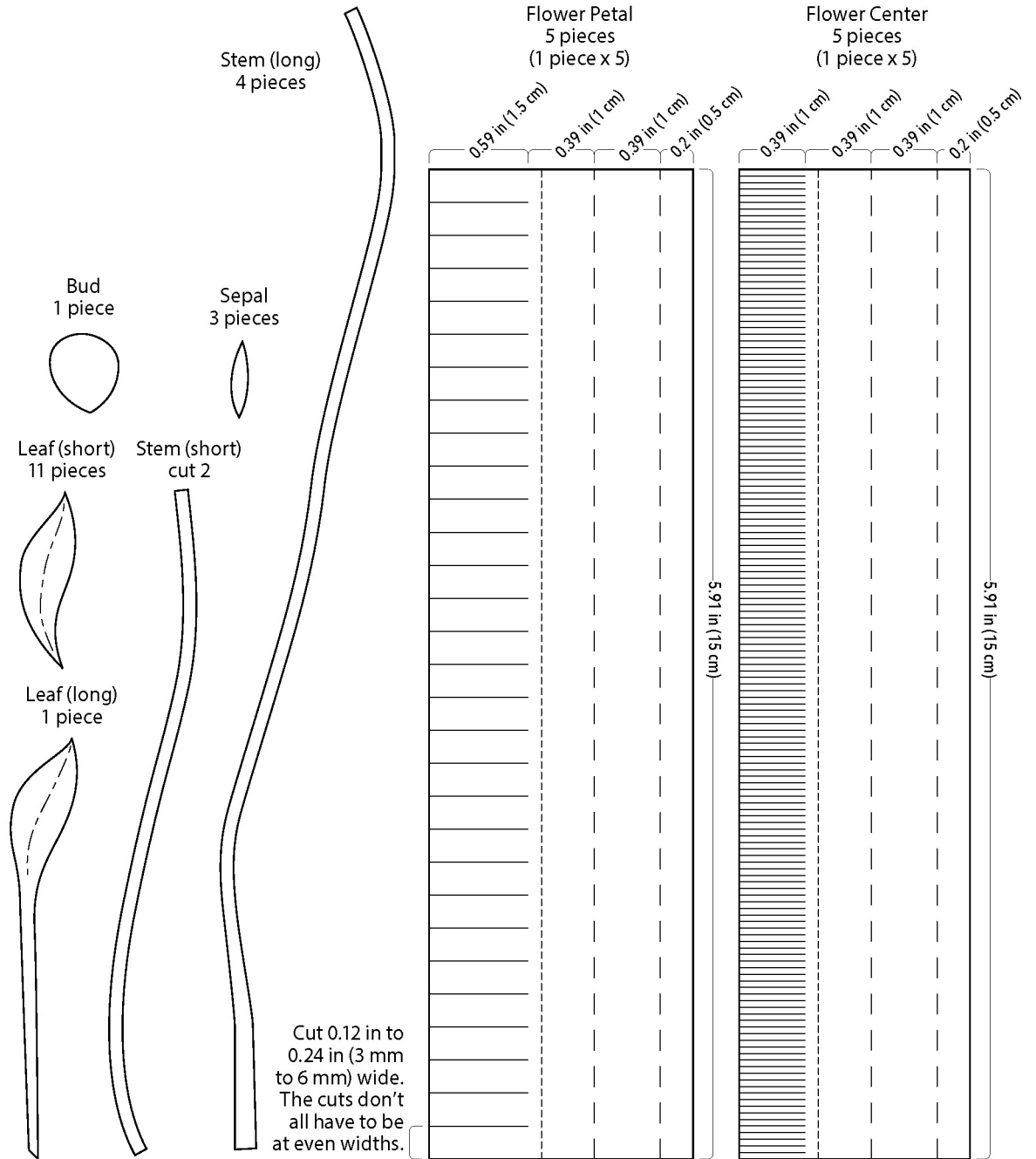

Aster

Photo on page 48 Instructions on page 103

- Emboss line -----
- Line to cut later - - - - -
- Dashed fold line (valley fold) - - - - -
- Dotted fold line (mountain fold, align pattern to crease)

Paper shown in photo

Flower Petal, Flower Base: Tant (L-73 — gray-pink)
 Flower Center: Tang (L-57 — pale orange)
 Leaf, Stem: Satogami (Shida / Fern — medium gray-green)

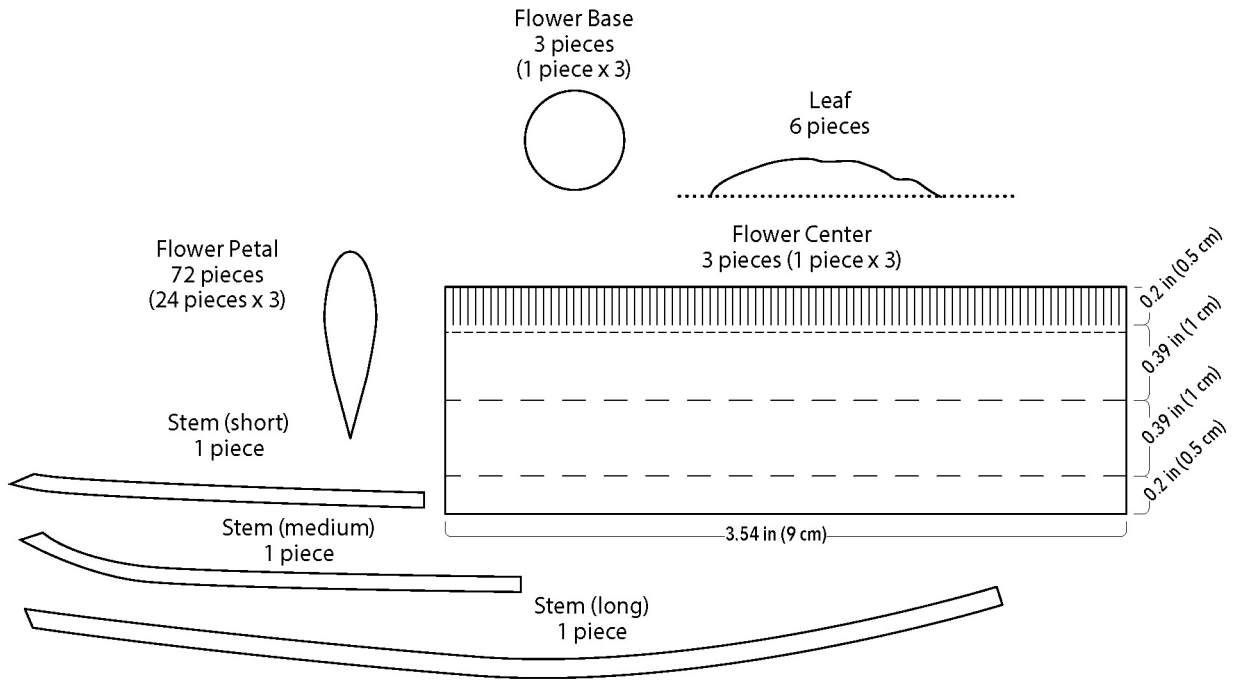

Marsh Mallow

Photo on page 49 Instructions on page 104

Paper shown in photo

Flower Petal: Tant (E-50 — pale purple)
 Flower Center: Canson Mi-Teintes (352 — orchid)
 Sepal, Leaf: Satogami (Shida / Fern — medium gray-green)
 Stem, Leaf Stem: Tant (G-63 — pale gray-green)

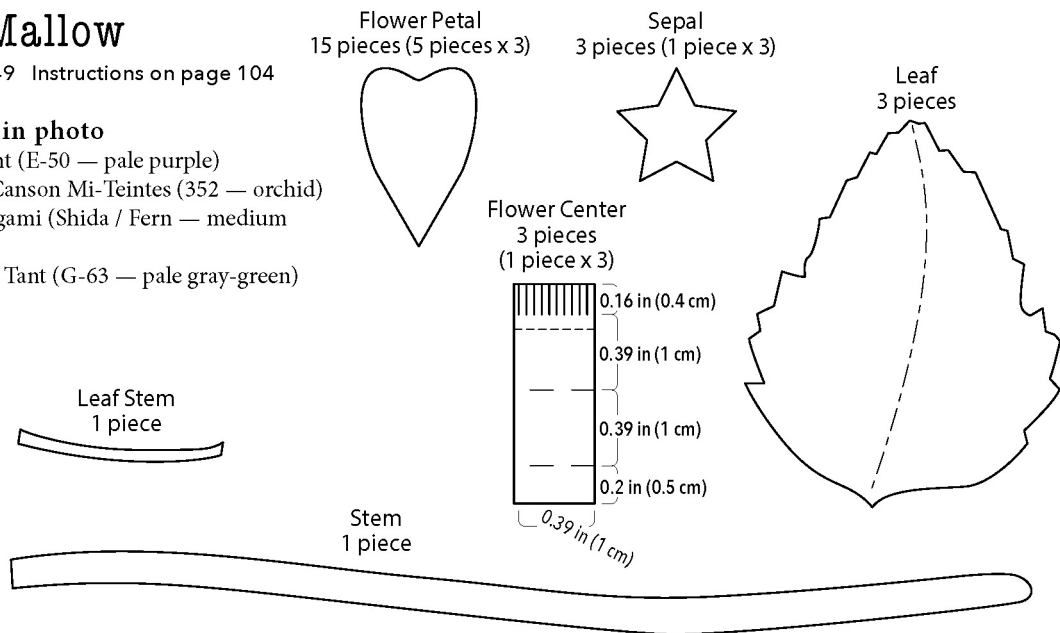

Grape

Photo on pages 50-51 Instructions on page 105

Paper shown in photo

Grape: Satogami (Ayame — medium purple, Kikyo — light purple), Tant (H-72 — dark gray-purple)
 Leaf: Tant (D-61 — medium leaf green), Mermaid (Olive)
 Vine, Tendril: Tant (H-58 — olive green)

Emboss line -----
 Line to cut later - - - - -
 Dashed fold line (valley fold) - - - - -
 Dotted fold line (mountain fold, align pattern to crease)

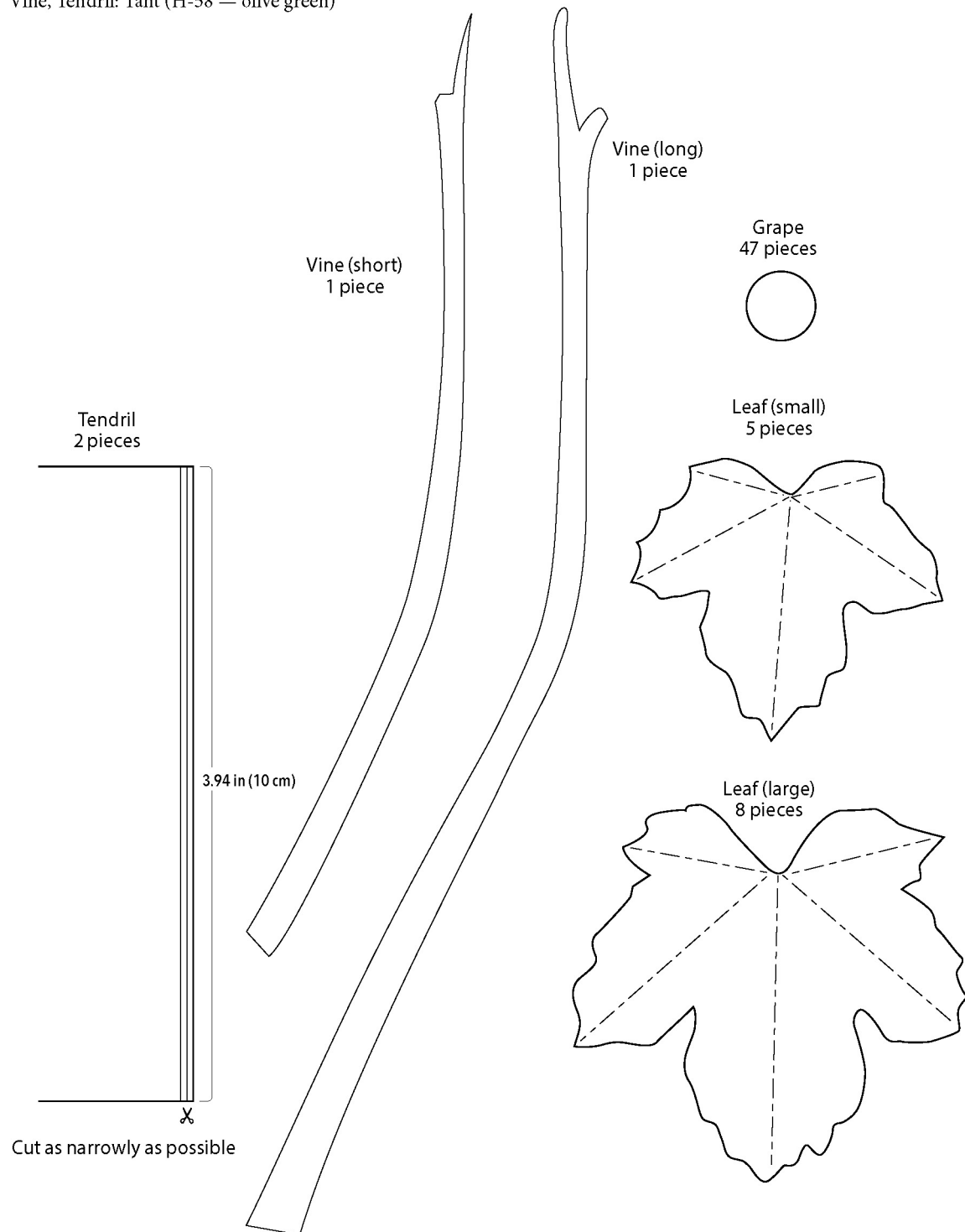

Wheat

Photo on page 52 Instructions on page 105

Paper shown in photo

Kernel: Satogami (Karashi / Mustard — light brown, Ukon / Turmeric — light brown)
 Spike, Leaf, Stem: Satogami (Ukon / Turmeric — light brown)

Emboss line -----
 Line to cut later - - - - -
 Dashed fold line (valley fold) — — —
 Dotted fold line (mountain fold, align pattern to crease)

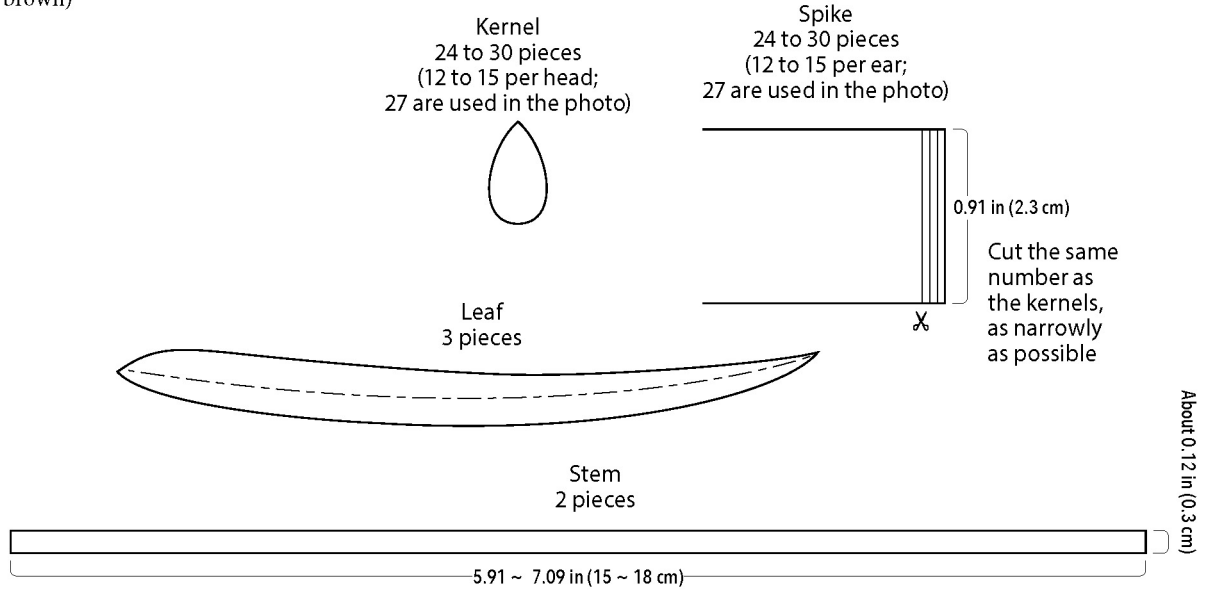

Meadow Saffron

Photo on page 53 Instructions on page 106

Paper shown in photo

Flower Petal: Canson Mi-Teintes (352 — orchid), Satogami (Kikyo — light purple)
 Stamen: Canson Mi-Teintes (400 — canary)
 Stem: Satogami (Kozo — light brown)

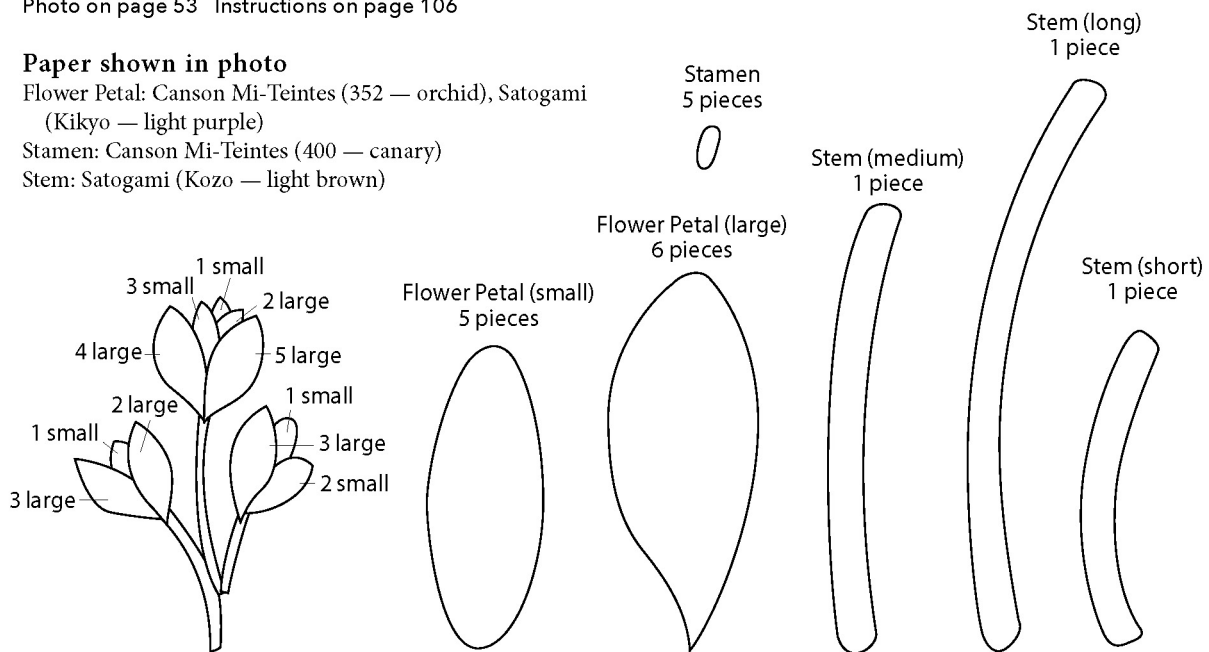

Olive

Photo on page 54 Instructions on page 106

Paper shown in photo

Olive: Canson Mi-Teintes (503 — burgundy)
 Leaf: Satogami (Matsu / Pine — forest green)
 Stem: Satogami (Susuki — medium leaf green)

Emboss line -----
 Line to cut later - - - - -
 Dashed fold line (valley fold) - - - - -
 Dotted fold line (mountain fold, align pattern to crease)

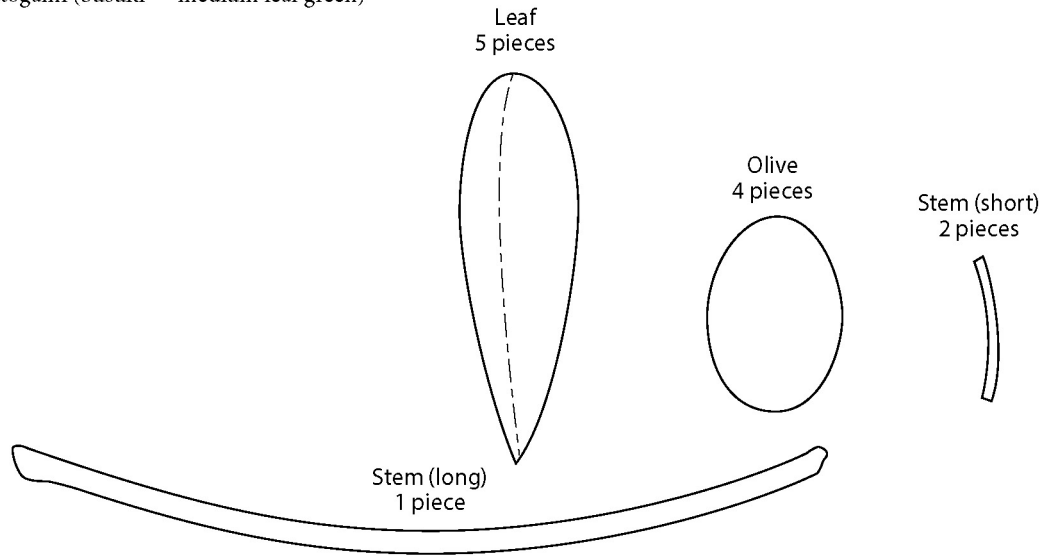

Christmas Rose

Photo on page 58 Instructions on page 107

Paper shown in photo

Flower Petal, Flower Base: Tant (P-64 — very pale green)
 Flower Center: Tant (L-57 — light beige-brown)
 Leaf, Stem: Mermaid (Blue Bamboo)

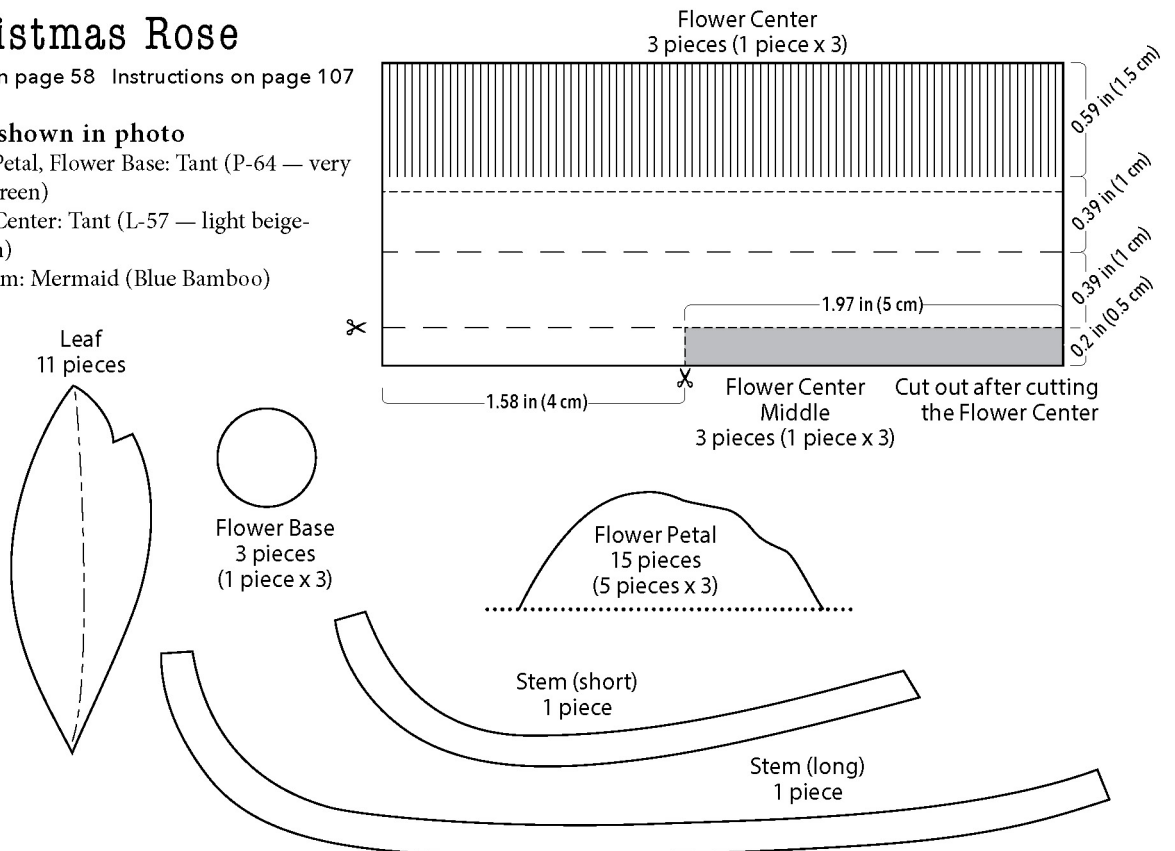

Winter Aconite

Photo on pages 60-61 Instructions on page 108

Paper shown in photo

Flower Petal, Flower Center, Flower Base: Satogami (Nanohana — pale lemon)

Bract, Bract Base: Satogami (Take/Bamboo — blue-green)

Emboss line -----
 Line to cut later - - - - -
 Dashed fold line (valley fold) - - - - -
 Dotted fold line (mountain fold, align pattern to crease)

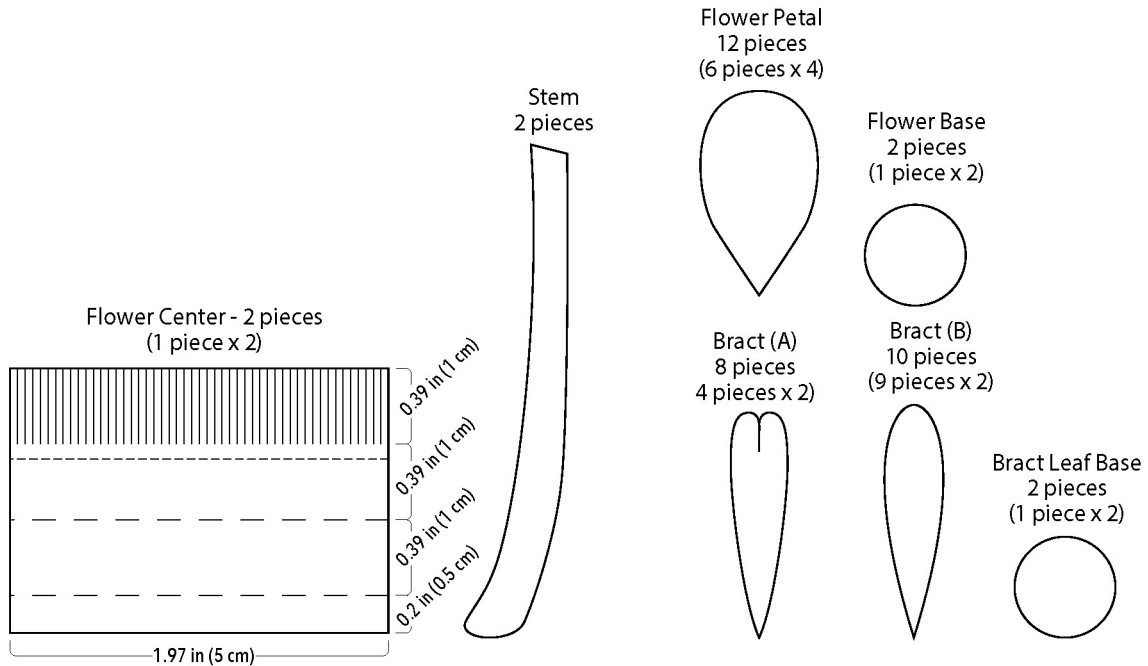

Cyclamen

Photo on page 62 Instructions on page 109

Paper shown in photo

Flower Petal, Flower Base: Tant (G-50 — light pink),
 Canson Mi-Teintes (352 — orchid)

Leaf: Satogami (Shida / Fern — medium gray-green)

Stem: Satogami (Matsu / Pine — forest green)

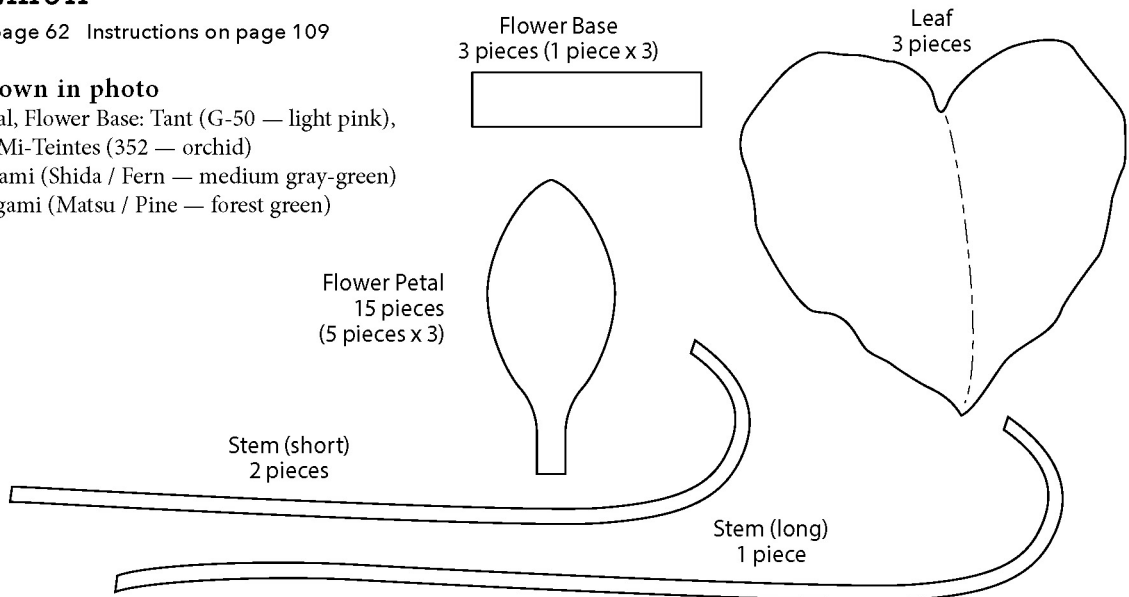

Primrose

Photo on page 59 Instructions on page 110

Paper shown in photo

Flower Petal, Flower Base: Canson Mi-Teintes
(400 — canary)

Flower Pattern: Tant (N-57 — light orange)

Leaf, Sepal: Tant (D-61 — medium leaf green)

Emboss line — — — — —
Line to cut later - - - - -
Dashed fold line (valley fold) — — — — —
Dotted fold line (mountain fold, align pattern to crease) ·········

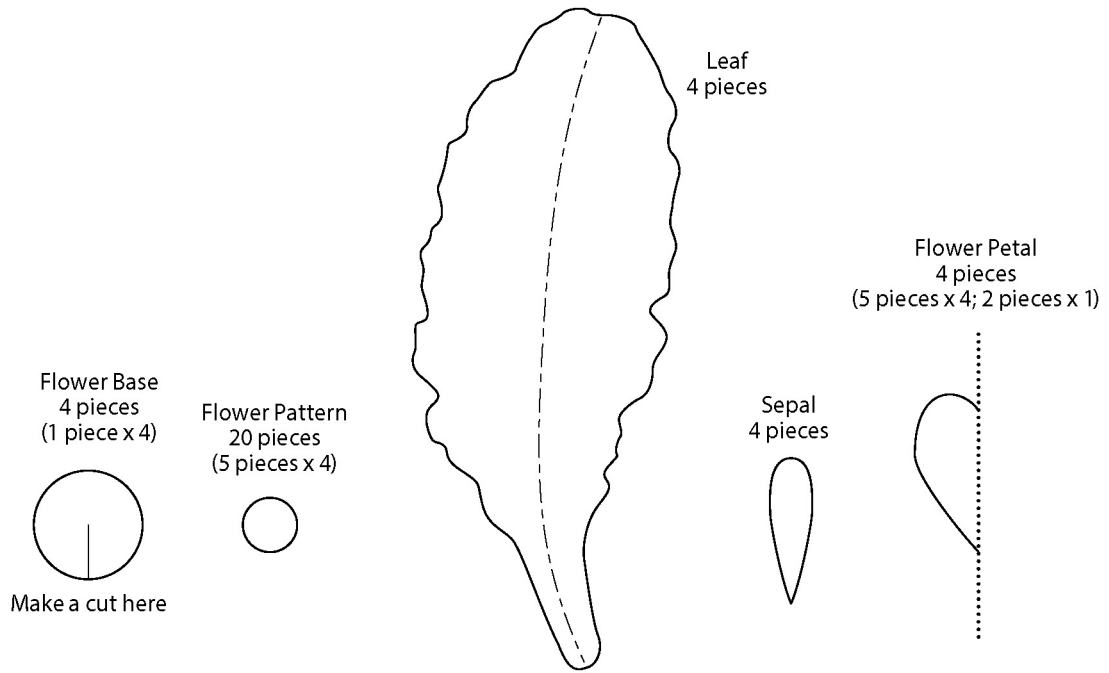

Glory of the Snow

Photo on page 66 Instructions on page 111

Paper shown in photo

Flower Petal: Tant (L-72 — light purple)

Flower Center: Satogami (Nanohana — pale lemon)

Flower Center Surround: Tant (P-72 — very pale purple)

Leaf: Satogami (Take / Bamboo — blue-green)

Stem: Satogami (Wara — straw)

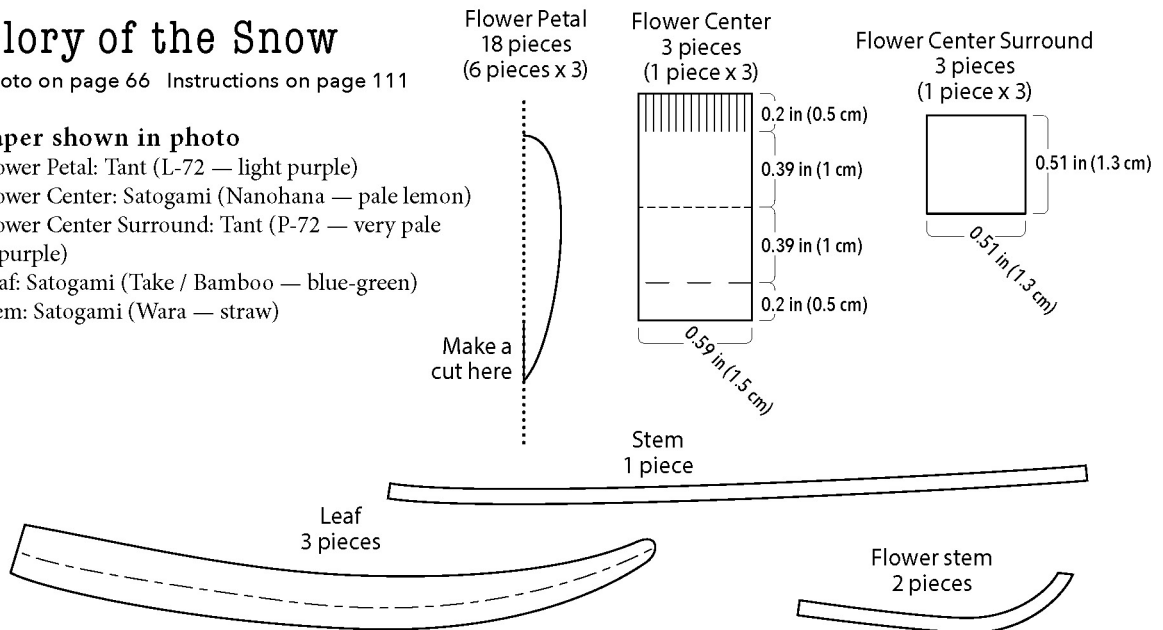

Holly

Photo on pages 64-65 Instructions on page 112

Paper shown in photo

Berry: Satogami (Adzuki — reddish-brown)

Leaf: Mermaid (Olive)

Stem: Satogami (Tobi — medium beige)

Emboss line -----
 Line to cut later -----
 Dashed fold line (valley fold) - - - - -
 Dotted fold line (mountain fold, align pattern to crease)

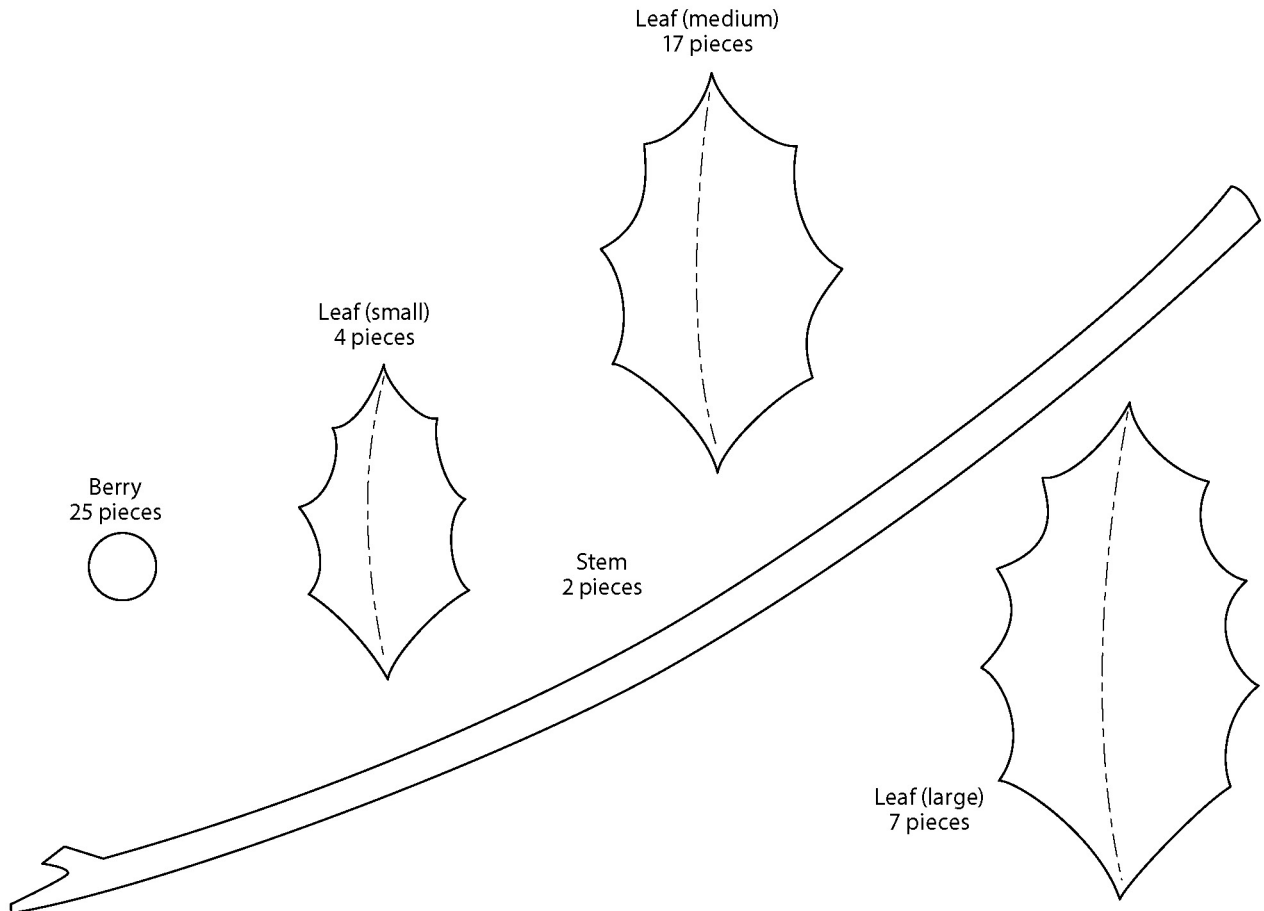

Snowdrop

Photo on page 67 Instructions on page 112

Paper shown in photo

Flower Petal: Mermaid (Natural — off white)

Bract: Satogami (Shida / Fern — medium gray-green)

Sepal, Leaf, Stem: Satogami (Take / Bamboo — blue-green)

